

Surveyaan V1

Flight Operator Manual Rev1.4

Document ID: SV-09

April 17, 2024



Revision History

Rev. No.	Release Date	Prepared/ Revised By	Reviewed/ Approved By	Revision Details
1.0	29-Sep-2023	Nischith Raj K G	Amit Raushan	First Release of the Document
1.1	01-Dec-2023	Nischith Raj K G	Amit Raushan	Section 8: Added Life of Drone
1.2	18-Dec-2023	Nischith Raj K G	Amit Raushan	<ol style="list-style-type: none"> 1. Manual Controller Added 2. Manual Mode Added 3. Updated C2 Data Link Loss Strategy
1.3	15-March-2024	Nischith Raj K G	Amit Raushan	<ol style="list-style-type: none"> 1. Updated Safety Instructions 2. Included GCS app version information 3. Added user removable nut bolt section
1.4	17-April-2024	Nischith Raj K G	Amit Raushan	Updated the model name to "Surveyaan V1"

Using this Information Booklet

Read Before the First Flight

The following information has been produced to help users make full use of the **Surveyaan V1**.

Watching all the tutorials videos and reading the disclaimer before flight is recommended. Refer to this manual for more comprehensive information.

Watch the Video Tutorials

Please watch the tutorial video below to learn how to use Surveyaan V1 correctly and safely.

https://www.youtube.com/playlist?list=PLx22dBN0WEZLK_Iw0eWBNGTiVbwCPaLnf

Download the Control Application

Make sure to use the Surveyaan V1 Control App to control the aircraft. To download the app, go to Android Play Store and install it or scan the QR code shown below.

<https://play.google.com/store/apps/details?id=com.surveyaan.application>



CONTENTS

Revision History	2
Using this Information Booklet	3
CONTENTS	4
List of Figures	7
1. Product profile	8
1.1 Introduction	8
1.2 What's In the Box	8
1.3 Featured Highlights	9
1.4 Technical Specifications	10
1.5 Aircraft Diagrams	12
1.6 Ground Control System (GCS)	15
2. Aircraft	17
2.1 Flight Controller	17
2.2 Operational Envelope	17
2.3 Performance	18
2.3.1 Speeds	18
2.3.2 Endurance	18
2.3.3 Operational Altitude	18
2.3.4 Ceiling Height	18
2.4 Motor/Electronic Speed Controllers	18
2.5 Flight Modes	20
2.6 Positioning System	21
2.7 Status lights	22
2.8 Geo-Fencing Capability	23
2.9 Flight Data Logging Capability	23
2.10 Payload Camera	23
2.11 Aircraft Battery	24
3. Ground Control System (GCS)	25
3.1 Ground Unit	25
3.2 Android Device with Controller	25
3.3 Tripod	26

4. Battery Charging	26
4.1 Charger.....	26
4.2 Charging the Aircraft Battery	29
4.3 Charging the Ground Unit Battery	30
4.4 Camera Charging.....	31
5. Surveyaan V1 Ground Control App.....	32
5.1 Installing the Software	32
6. Flight Procedures	35
6.1 Assemble the Aircraft.....	35
6.1.1 Mounting the Propeller.....	35
6.1.2 Mounting the Camera	36
6.1.3 Mounting the Antenna.....	37
6.1.4 Mounting the Aircraft Lithium Ion Battery	37
6.1.5 Preparing the Ground Unit.....	38
6.1.6 Camera in Pairing Mode.....	40
6.2 Connect Surveyaan V1 Ground Control App.....	40
6.3 Flights Mission.....	43
6.3.1 General/Land Survey Mission	44
6.3.2 Types of Rooftop Scan Mission:	45
6.3.3 Corridor Mapping Mission	47
6.3.4 Resume Mission	48
6.3.5 Take off	49
6.4 Manual Control	49
6.5 Aircraft Settings.....	50
6.5.1 Accelerometer Calibration	50
6.5.2 Compass Calibration	53
6.5.3 Gyro Calibration	55
6.5.4 Geo-fence Setting	55
6.5.5 Logs	58
6.5.6 Logout	60
6.6 Aircraft landing and repacking everything.....	60
6.7 Preflight checklist.....	61
6.8 Post flight routine	62

6.9 Continuous Flight Monitoring	62
6.10 Failsafe and Emergency contingencies	62
7. Data Link.....	63
7.1 Description & Specification.....	63
7.2 Full Functioning.....	65
7.3 Visual & Aural Alert on Communication Loss	65
7.4 Communication Range.....	67
7.5 Data link Loss Strategy and Other Contingencies	68
7.5.1 Data link loss strategy	68
7.5.2 Battery Failsafe	68
7.5.3 Geo-fence Breach.....	68
8. Life of Drone.....	69
9. User Removable Nuts and Bolts.....	70
10. Safety Instructions & Precautions.....	74
11. Troubleshooting.....	75
11.1. Drone Not Connected	75
11.2. Motor and Propeller Problems	76
11.3. Camera Connection issues	76
11.4. Error Messages and Indicators.....	77
12. Warranty Terms & Conditions	80
13. Customer Support.....	83
14. Policy Update	83

List of Figures

Figure 1: Surveyaan V1 Box.....	8
Figure 2: Geo - Fencing.....	23
Figure 3: Battery Charger Connecting Diagram.....	29
Figure 4: Battery Charger Connecting Diagram.....	29
Figure 5: Surveyaan V1 Login/Registration Page	33
Figure 6: Surveyaan V1 App Main Screen View.....	41
Figure 7: General/Land Survey Mission.....	44
Figure 8: General Rooftop Scan Mission.....	45
Figure 9: Circular Rooftop Scan.....	46
Figure 10: Corridor Mapping.....	47
Figure 11: Resume Mission Icon	48
Figure 12: Manual Control.....	49
Figure 13: Accelerometer Calibration	53
Figure 14: Compass Calibration.....	54
Figure 15: Communication Lost Message.....	66
Figure 16: Communication Regained Message	67
Figure 17: Surveyaan V1 GCS app main dashboard	77
Figure 18: Compasses Inconsistent GCS Message.....	78
Figure 19: GPS Error message	78
Figure 20: Firmware Not Authenticated GCS error message.....	79
Figure 21: Hardware IDs not matching Error message.....	79

1. Product profile

1.1 Introduction

Surveyaan V1 is a high quality and affordable aerial surveying machine with class-leading agility and speed, redundant components for reliability, and an intuitive android application which makes traditional remote-control operation, a thing of the past. Hero10 Black camera can be easily be integrated with the aircraft.

1.2 What's In the Box

Surveyaan V1 package is just 50 cm x 50 cm suitcase which weighs around 4 kg and can easily be carried on field even if only one person is going for the survey.



Figure 1: Surveyaan V1 Box

Surveyaan V1 drone	1	Pair of Propeller	2
Ground Unit	1	Surveyaan V1 Battery	1
Hero10 black camera	1	Antenna	2
Battery Standard Charger	1	Tripod & Holder	1 each
Flight Operator Manual	1	Maintenance Kit	1
Surveyaan V1 Goodies	Included	Necessary Cables	Included
Warranty Certificate	Included	Android Device with Controller	1

1.3 Featured Highlights

Fast and Easy: Mechanical design, along with the self-tightening propeller and foldable ground control station makes Surveyaan V1 easy to carry, store and prepare for the flight.

Camera: Surveyaan V1 comes integrated with HERO 10 Black. It shoots 5.3K video with higher frame rates and game changing Hyper Smooth 4.0 video stabilization, captures 23 megapixel photos.

Weight: Aircraft weighs approx. 2kg and falls under the micro category according to Drone Rules, 2021.

Flight Controller: Aircraft is powered by robust flight controller to provide a safer and reliable experience in accordance with regulations.

1.4 Technical Specifications

Aircraft	
Classification of UAS	Micro
Category of the UAS	Rotorcraft
Sub-category of UAS	RPAS
Weight without battery & without payload	1.154 Kg
Weight with battery but no payload	1.782 Kg
Maximum all-up-weight (including payload) in kg	2 Kg
Overall dimensions (l x b x h) in mm	L: (633.71±2), B: (633.71±2), H: (265.53±2)
Max Diagonal Length (including propellers)	791 mm
Details of Compatible Payload	23MP RGB Camera
Motor	BLDC
Number of Motors	4
Power Rating	272 Watts
Propeller Details	Diameter - 10 inches , Max RPM - 9857
Frequency Band	2405 – 2480 MHz
Maximum Flight Time	23 Minutes
Maximum Range (in km)	1.5km radius
Maximum speed (in m/s)	10 m/s
Max Tilt Angle	±30 degree
Maximum height attainable/Maximum Operational height (in m) (AMSL)	2100 m
Ceiling Height (in m) (AGL)	120 m

Operational Envelope	VLOS operations Only (within the operations/performance limitations i.e., 120m altitude and 1500m radial range)
Camera	
Model	HERO10 Black
Photo	23MP GPS Tagged Image
Video	5.3K60, 4K120+2.7K240 Wide FOV
Weight (including mounting Buckle)	180 gm
Connected Features	Built-In Bluetooth
Other Features	Built-In Mounting with Folding Fingers
Supported SD Cards	Micro SD, Max Capacity: 128GB,
Battery	1720 mAh lithium-ion
Use Case	Surveying & Video Recording
Ground Unit	
Operating Frequency	2405 – 2480 MHz
Maximum Transmission Distance	1.5km(Unobstructed, free of Interference)
Operating Voltage	7.4V
Battery/Cells	2 x Li-ion 2000 mAh Cells
UAS Battery	
Capacity	10200 mAh
Nominal Voltage/Max. Voltage	14.4V/16.8V
Battery Type	Li-ion 4S
Energy	146.88Wh
Net Weight	630 gm
Operating Temperature	Charging: 10°C to 45°C Discharging: -10°C to 50°C

Charger	
Voltage	16.8V
Rated Power	50W
Manual Controller	
Android Device with Controller	GameSir X2
Others	
Tripod	9ft tripod stand
Holder	Ground unit Holder

Table 1: Surveyaan V1 Technical Specification

1.5 Aircraft Diagrams

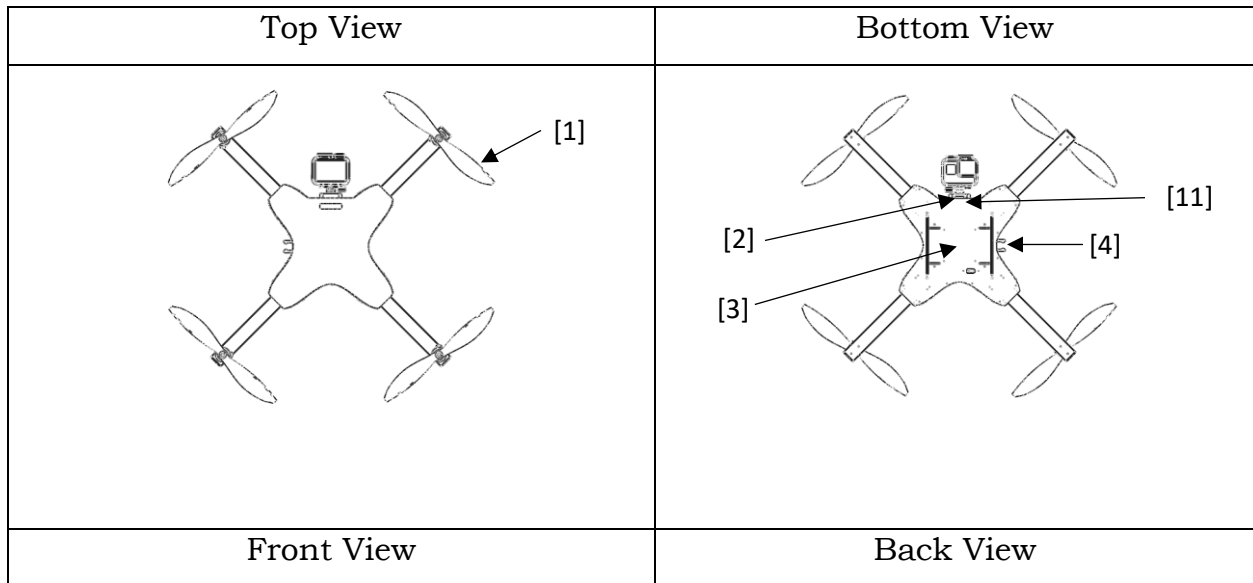

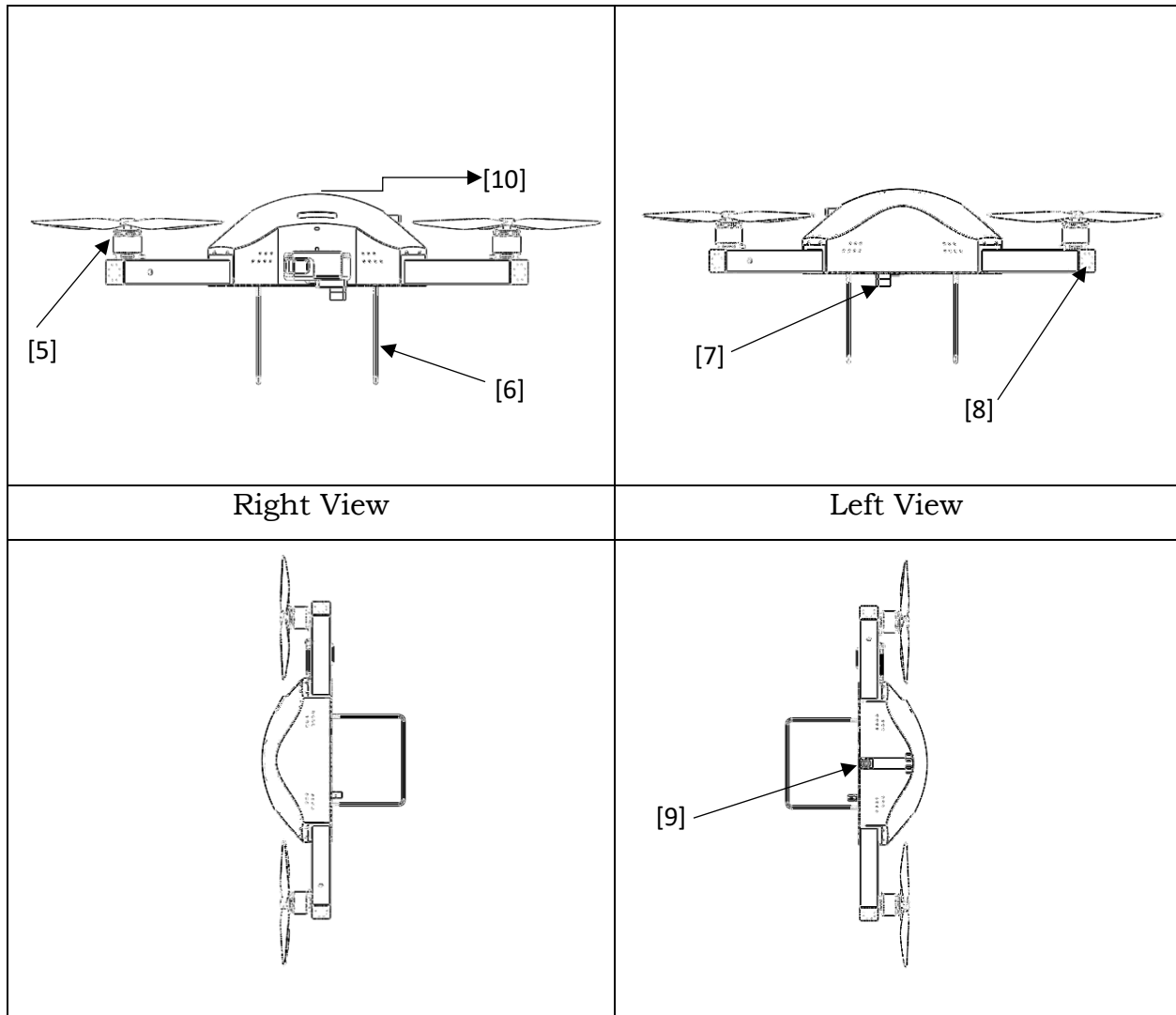

- [1] Propeller
- [2] Camera Mounting Space
- [3] Battery Mounting Space
- [4] Antenna Lock
- [5] Motor
- [6] Landing Gear
- [7] Power Port

[8] Status Lights

[9] Antenna Connector

[10] GPS

[11] UIN Plate

1.6 Ground Control System (GCS)

GCS has two components: a Ground Unit with a Wi-Fi Module and an Android Mobile Device with Controller.

1. Ground Unit

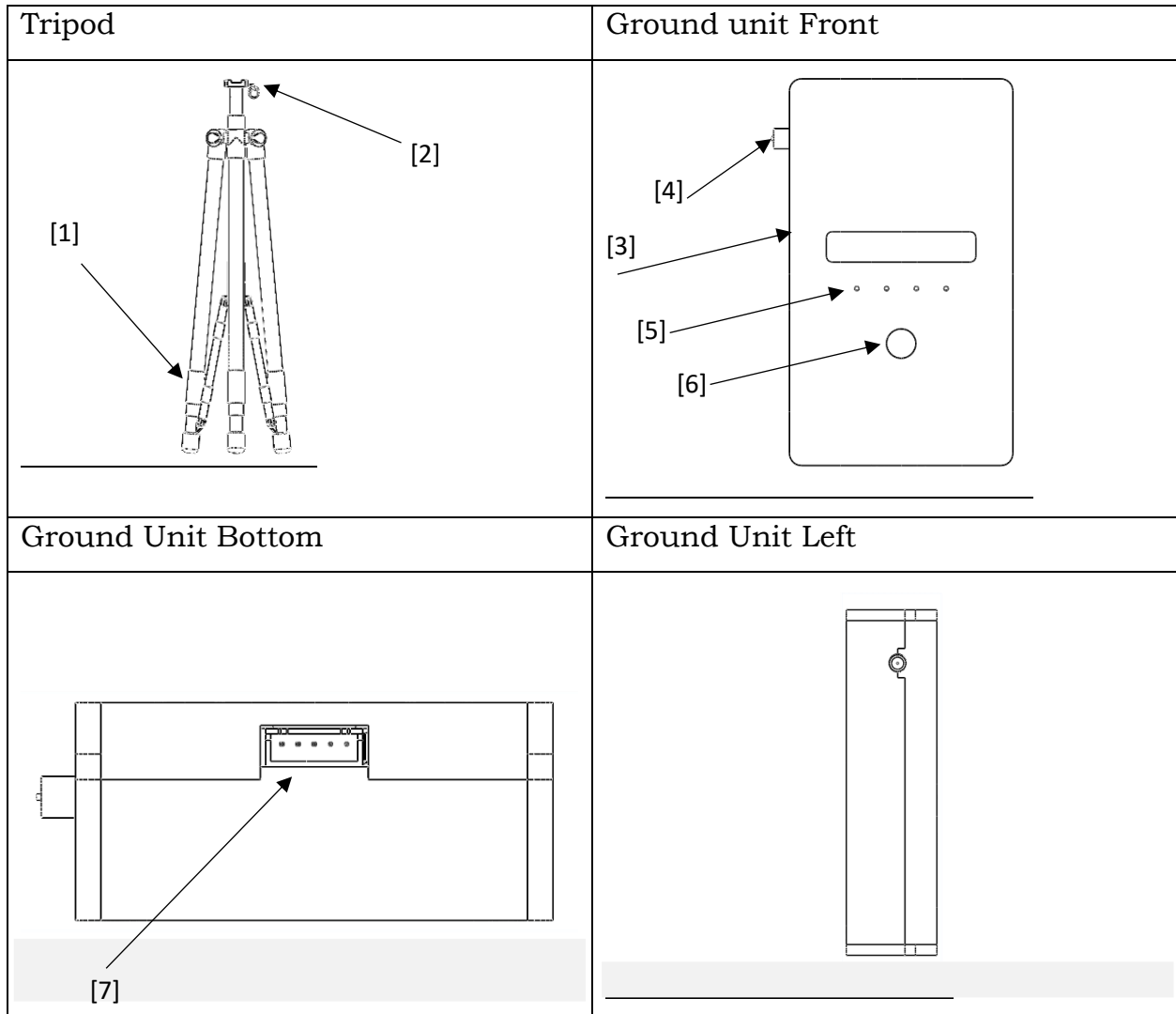

[1] Foldable and Telescoping Legs

[2] Ground Unit Mounting Space

[3] Ground Unit

[4] Antenna Port

- [5] Status LEDs
- [6] Ground Unit Power Switch
- [7] Ground Unit Charging Port

2. Android Device with Controller

An Android mobile device serves as Drone Controller. It runs drone control software, which communicates with the drone through the ground unit. A controller is integrated with the Android Mobile Device for the user to take the manual control.

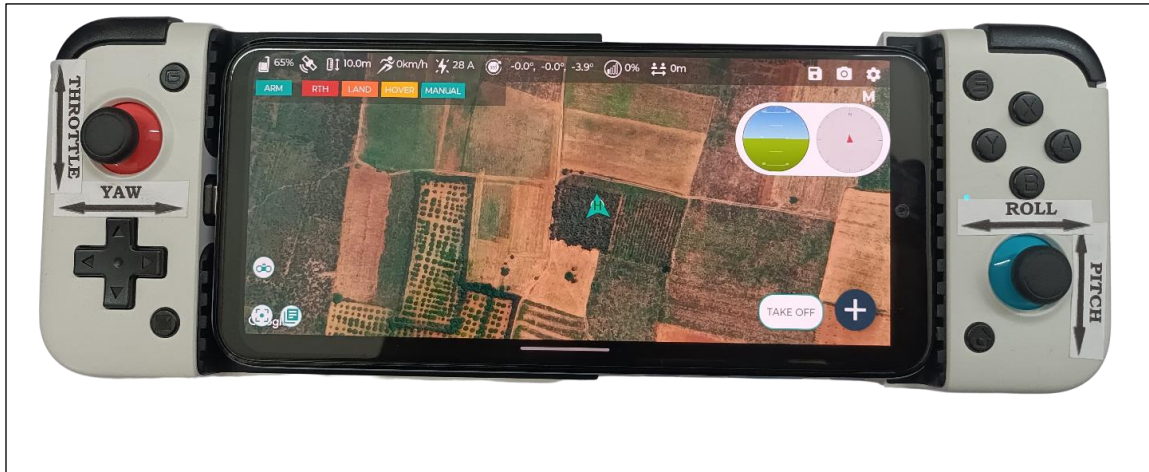

2. Aircraft

2.1 Flight Controller

Aircraft is powered by robust flight controller to provide a safer and reliable experience in accordance with Drone Rules, 2021. It includes safety modes such as detecting battery failsafe and initiate to returning to home location. It can also critical flight data from each flight. It provides the feature to customize the geofence.

2.2 Operational Envelope

The operational envelope is the defined range of conditions within which a system operates safely and efficiently. It encompasses factors like environmental conditions, load capacities, and speed, ensuring optimal performance while maintaining safety. Operational Envelope for the Surveyaan V1 has been tabulated below.

Parameter	Description
Maximum calculated altitude as per design	2100 m (AMSL)
Max Operational Altitude above ground level	120 m AGL
Maximum horizontal range of Drone from home	1500 m
Maximum Horizontal speed	10 m/s
Operational speed*	10 m/s
Operational temperature	-10°C to 50° C
Maximum wind speed resistance	25 Km/h or 6.9 m/s
Max. Endurance	23 minutes
Maximum Take-off weight including payload (MTOW)	2 Kg

Payload Weight (including mounting buckle)	180 gm
---	--------

* Speed can be changed by pilot controls in Manual mode not exceeding 10 m/s.

2.3 Performance

2.3.1 Speeds

Maximum Operating Speed: The aircraft can reach the maximum horizontal speed of 10 m/s during the flight.

2.3.2 Endurance

The Surveyaan V1 exhibits an impressive endurance, allowing for continuous flight for up to 23 minutes on a single battery charge. With its extended flight time, it can map up to 60 hectares of land in a single charge when flown at an altitude of 120 meters and with a 70 percent side overlap.

2.3.3 Operational Altitude

Surveyaan V1's maximum operating altitude is 2100 m (above mean sea level).

2.3.4 Ceiling Height

Maximum operational altitude of Surveyaan V1 is restricted to 120 m above ground level (AGL) for a safe and efficient operation. Using Surveyaan V1 ground control app operator can fly the drone at any height up to 120m.

2.4 Motor/Electronic Speed Controllers

Electronic Speed Controllers (ESCs) play a crucial role in protecting the motor from damage and ensuring safe operation of the aircraft.

Electronic Speed controller (ESC) used in the UAS is equipped with the following protection:

1. Start-up Protection: The ESC will shut down the motor when it fails to start the motor. In this case, you may need to restart the motor after inspecting for possible causes like poor connection or disconnection between ESC and motor wires, blockage of propellers, etc.

2. Throttle Signal Loss Protection: When the ESC detects loss of signal for couple of seconds, it'll cut off the output immediately to avoid greater loss which may be caused by the continuous high-speed rotation of propellers or rotor blades. ESC will resume the corresponding output when normal signals are received.

3. Motor Lock-up protection: The ESC will try to restart the motor (thrice) when motor lock-up is detected, if it fails, it will cut off the output and stop attempting.

4. Short Circuit/Over current protection: In the event of a fault condition or a short circuit, the electronic speed controller (ESC) will promptly discontinue its output. This action serves to safeguard the motor from potential damage or adverse effects caused by excessive current, ensuring the overall integrity of the system.

5. Overheating protection:

The Electronic Speed Controller (ESC) is equipped with an overheating protection feature. ESC cuts off the power to the motor once its temperature rises to 100°C.

2.5 Flight Modes

The following flight modes are available for Aircraft:

I. Guided Mode:

Whenever the aircraft is commanded to trace a particular path (or waypoint) from the control application, the aircraft enters Guided Mode. This mode works best when the aircraft has strong GPS, barometer, and compass signal. The aircraft utilizes abovementioned sensors to automatically stabilize itself, and to navigate to the requested waypoints.

II. Return to Launch (RTL):

This mode uses GPS and barometer for the positioning of aircraft. Aircraft can be requested to enter this mode by clicking on RTH button from Surveyaan V1 control application. Once this mode is triggered, the aircraft will be interrupted from its original mission and will navigate and land back to its home location*.

*Home location is the location from where the aircraft took off. While taking off from the home location aircraft saves the home location to use it in case of RTL command.

III. Land:

This mode doesn't use the GPS signal. Aircraft can be requested to enter this mode by clicking on LAND button from the Surveyaan V1 control application. Once this mode is triggered, the aircraft current mission will be interrupted and will land immediately on the ground with help of barometer sensor feedback.

IV. Manual:

This mode allows the manual control of the drone. In this mode, the drone movement is controlled by the manual controller.

2.6 Positioning System

Aircraft uses Global Navigation Satellite System (GNSS) receivers and barometer for three-dimensional positioning of the aircraft. The 3D positioning system is critical for Guided and Return to Launch mode whereas altitude positioning system is critical for Land mode.

Specifications:

Parameter	Specification
GNSS Model	Ublox NEO M8N
Receiver Type	72-channel u-blox M8 engine GPS L1C/A, SBAS L1C/A, QZSS L1C/A, QZSS L1 SAIF, GLONASS L1OF, BeiDou B1I, Galileo E1B/C
Operational limits	Altitude 50,000 m
	Velocity 500 m/s
Horizontal Position accuracy	2.5 m (GPS & GLONASS)
Max Navigation update rate	5 Hz
Sensitivity	Tracking & Navigation -167dBm
Time-To-First-Fix	Cold start 26 s Hot Start 1s Aided Starts 2 s
Power Supply Voltage	2.7 V to 3.6 V
Backup Battery voltage	1.4 V to 3.6 V
Operating temperature	-40 to 85 °C
Storage temperature	-40 to 85 °C

Table 2: GNSS model specification

Functionalities of GNSS receivers

1. It is used to estimate the drone's position within meters of its actual location.
2. Helps in point to point navigation during the flight.
3. Helps in implementing Geo-fence Capability in the drone.

2.7 Status lights

Surveyaan V1 can be used for day operation only and thus there is no provision of strobe light. However it is equipped with status lights at the end of the arms which helps to identify the orientation of the drone.

Surveyaan V1 has 4 status LEDs installed at the end of its arm. The positions of these LEDs are shown in the figure below:

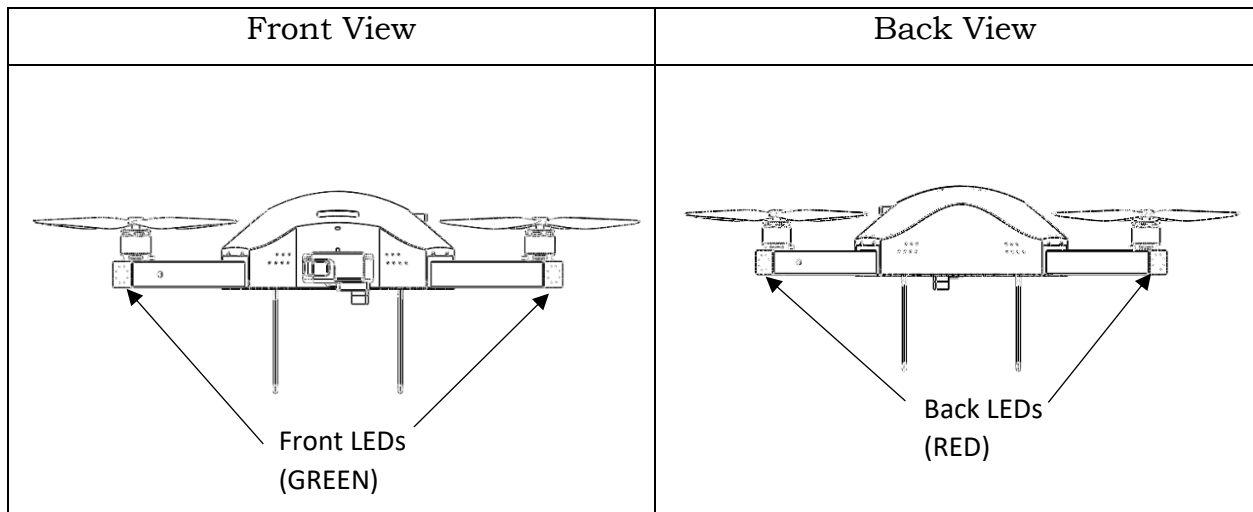

Table 3: Navigational Lights

LEDs at front blinks in GREEN color and LEDs at back blinks in RED color. It starts blinking at the rate of 1Hz once the drone successfully boots.

2.8 Geo-Fencing Capability

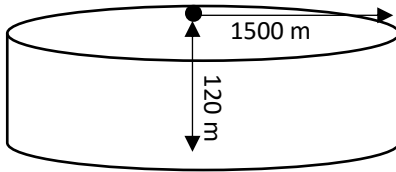

Figure 2: Geo - Fencing

Flight paths are restricted within a default 1.5 km geo-fence radius, ensuring planned paths remain within this limit. Any attempt to extend beyond triggers errors, preventing takeoff.

Additionally, there's an altitude ceiling at 120 meters, adjustable from 10 to 120 meters. Users have the flexibility to customize these defaults using the geo-fence slider in the Surveyaan V1 Ground Control App's [Aircraft Settings](#).

2.9 Flight Data Logging Capability

Flight data is automatically recorded to the internal storage of the aircraft. This includes aircraft stability values, battery information, and other necessary parameters. Detailed procedure to access the logs has been mentioned under the [Aircraft Settings](#).

2.10 Payload Camera

Aircraft currently supports HERO10 Black camera as payload.

Specifications:

Camera	
Model	HERO10 Black
Photo	23MP GPS Tagged Image
Video	5.3K60, 4K120+2.7K240 Wide FOV
Weight (including mounting Buckle)	180 gm

Connected Features	Built-In Bluetooth
Other Features	Built-In Mounting with Folding Fingers
Supported SD Cards	Micro SD, Max Capacity: 128GB, UHS-1 rating required
Battery	1720 mAh lithium-ion
Use Case	Surveying & Video Recording

Table 4: Camera payload specifications

Camera should be connected to the aircraft system via Bluetooth using Surveyaan V1 Ground Control App. More has been explained in [Assemble the Aircraft](#).

2.11 Aircraft Battery

Aircraft uses one 4S Li-Ion battery of 10,200 mAh capacity, a voltage of 16.8V. It can provide maximum of 23 minutes flight time. It should only be charged using an appropriate Surveyaan V1 approved charger.

The battery must be fully charged before taking the first flight. More about the handling of the battery has been explained in the maintenance manual.

3. Ground Control System (GCS)

GCS has two components: a Ground Unit with a Wi-Fi Module and an Android Mobile Device with Controller.

3.1 Ground Unit

Ground Unit connects the android mobile with the aircraft and acts as a bridge between both of them. The ground unit connects with mobile over Wi-Fi whereas it connects with aircraft over long range network. The SSID and password of the Ground Unit is mentioned on the back side. It is powered by lithium ion cells. It has a 5 pin port to charge the lithium chemistry battery pack using the same charger provided to charge the aircraft's battery. The box also has four blue color LED lights for indicating battery level and connection status.

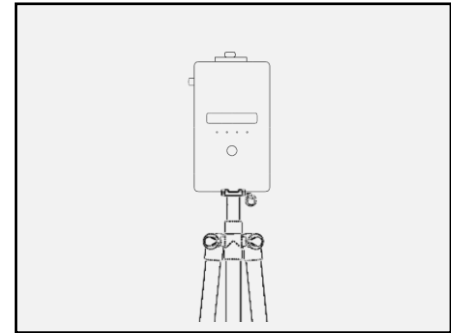

Once fully charged it can give battery backup up to 24hrs if continuously used.

More about the Ground Unit has been covered under [Preparing the Ground Unit](#) section.

3.2 Android Device with Controller

An Android mobile device serves as Drone Controller. It runs drone control software, which communicates with the drone through the ground unit. A controller is integrated with the Android Mobile Device for the user to take the manual control.

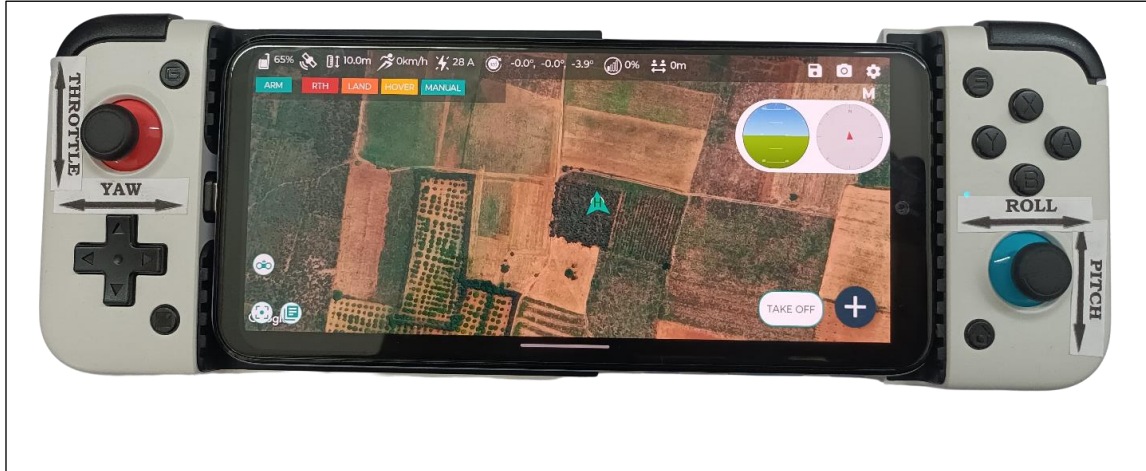

3.3 Tripod

A tripod is a portable three-legged frame or stand, used as a platform for supporting the weight and maintaining the height of the Ground Unit.

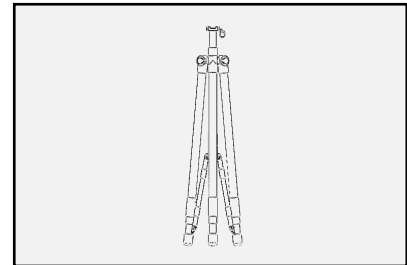

4. Battery Charging

4.1 Charger

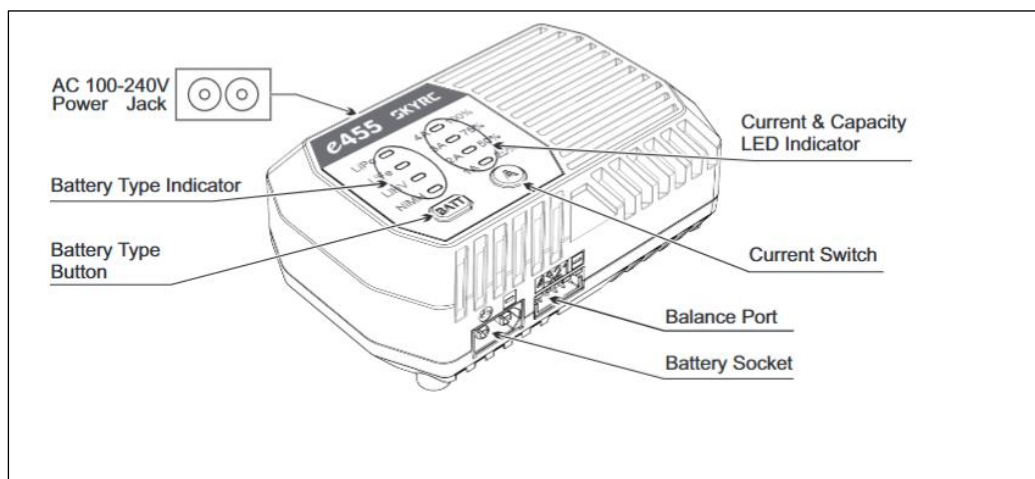

A standard charger is included in the package which is used to charge Aircraft as well as Ground Unit battery. The batteries should be charged in an optimum temperature ranging from 0 degree Celsius to 50 degree Celsius. The charger has various buttons and ports which has been explained below:

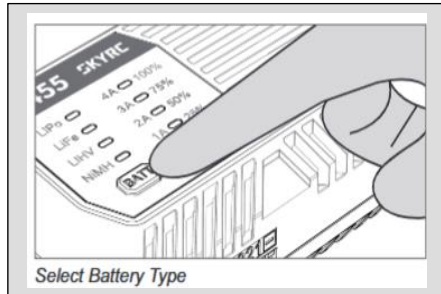

The charger has button named “BATT TYPE”. This button is used for selection of battery chemistry type. For our use case always keep chemistry type as LiPo.

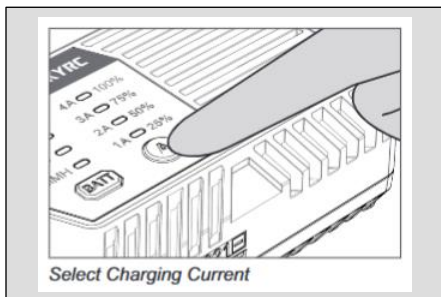

The charger has a second button as shown in the figure. This button is used for selection of current in Amperes. For our use case, we keep 4A for aircraft battery charging and 2A for ground control station charging.

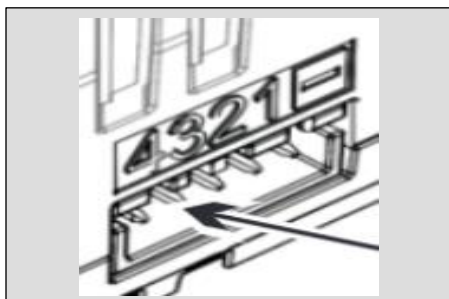

The charger has as shown in the image. The aircraft battery is of 4S configuration and ground control station is of 2S configuration.

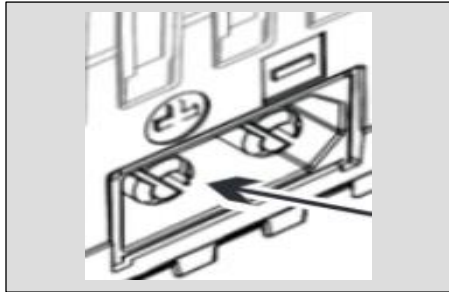

The charger has a battery power port in front named with “+” and “-” sign. This port get connected with XT60 cable supplied with the charger.

<i>EXPLANATION OF LED STATUS</i>				
25%	50%	75%	100%	
●	●	●	●	
25%	50%	75%	100%	
●	●	●	●	
25%	50%	75%	100%	
●	●	●	●	
25%	50%	75%	100%	
●	●	●	●	

Capacity<25%	25% capacity indictor LED flashing
25%≤Capacity<50%	50% capacity indictor LED flashing
50%≤Capacity<75%	75% capacity indictor LED flashing
75%≤Capacity<100%	100% capacity indictor LED flashing

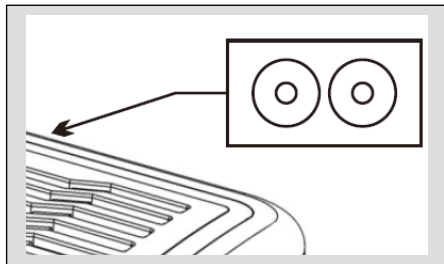

The charger has an AC power port. An AC cord is supplied with the charger, gets connected with it.

Aircraft Battery & Ground Unit Battery

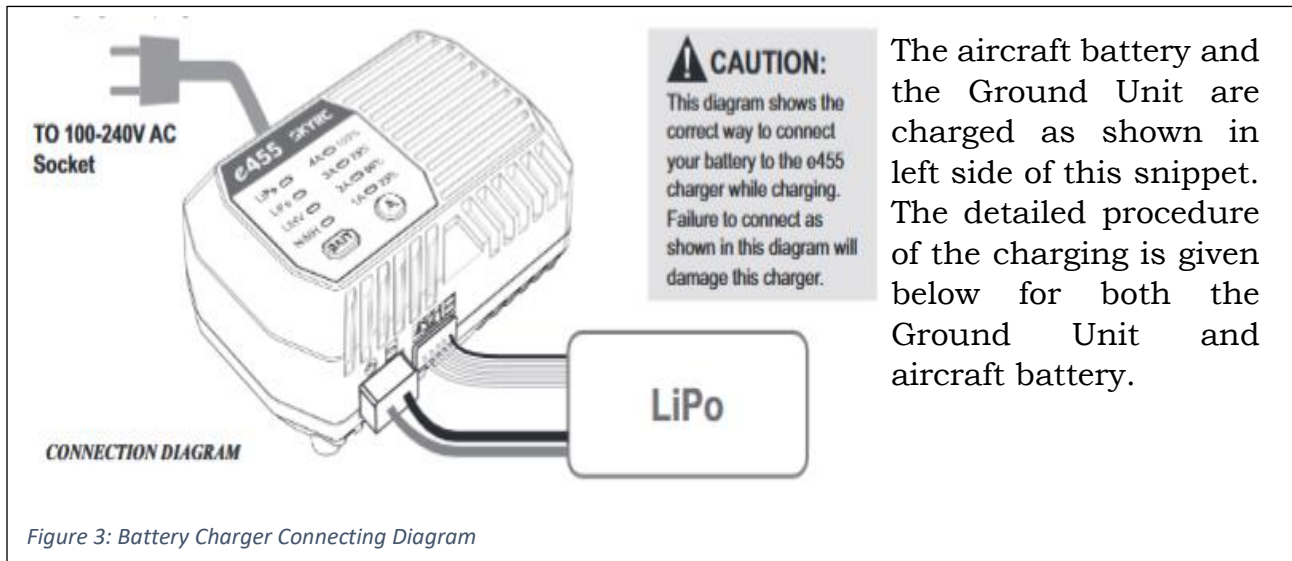

4.2 Charging the Aircraft Battery

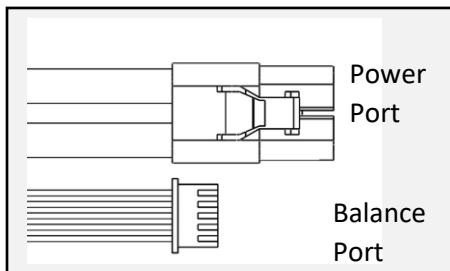

There are two ports on battery. The one is five pin balance port and another one is two pin power port.

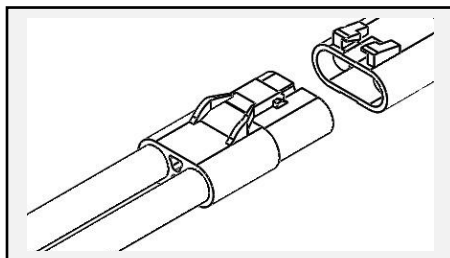

Connect the power port with its male part provided on charger and connect the balance port with its male part provided on right wall of the charger

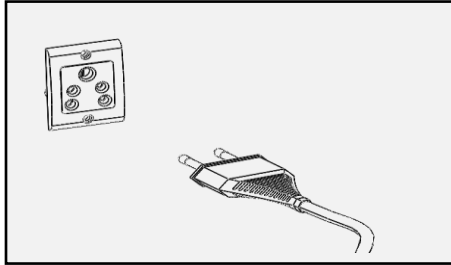

Make sure Lithium ion chemistry is selected on charger and then connect the AC chord with household AC power supply. Switch on the AC supply and charger will start charging the battery.

4.3 Charging the Ground Unit Battery

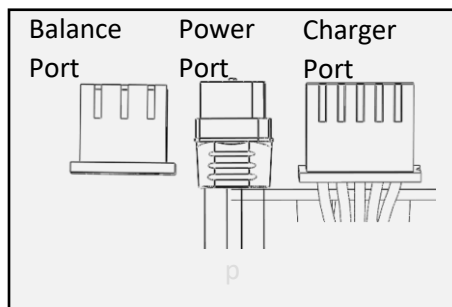

A charging cable is provided along with the Ground Unit. The cable has five pin connector at one end and battery balance and power port at another end.

Ground Unit Charging Port

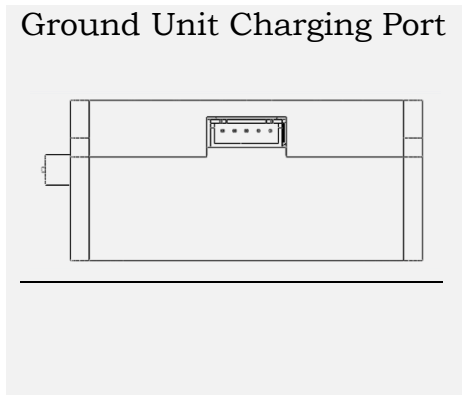

Charger port goes to the charging port of the Ground Unit, balance port goes to the balance port named 2S of the charger & power port with the mating power port of the charger.

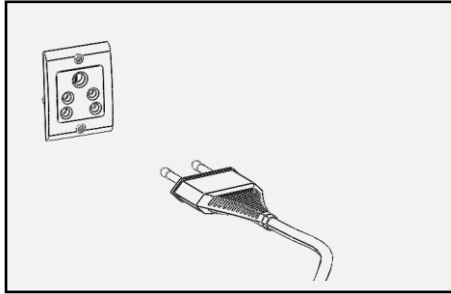

Select 2A as the charging current for the Ground Unit. Then switch on the charger's AC power similar to the procedure explained in aircraft battery charging section.

4.4 Camera Charging

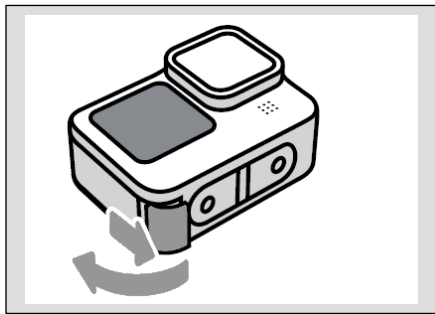

Unlock the door latch and flip the door open.

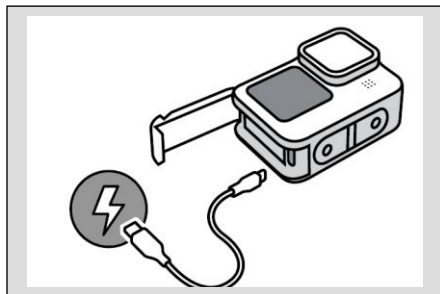

Connect the camera to a USB charger or computer using the USB-C cable included in package. It takes about 1 hours for the battery to fully charge. The camera status light will turn off when it's done. Unplug the cable and shut the door when charging is complete. Be sure the door latch is closed and locked before using your camera.

5. Surveyaan V1 Ground Control App

The Surveyaan V1 Ground Control App is a mobile application specifically designed to plan & fly Surveyaan V1 aircraft. This app is used to connect the camera with the aircraft, plan the flying path, configure and calibrate the aircraft.

App Details:

Developer	Nibrus Technologies Private Limited
App Version	3.09

5.1 Installing the Software

Install the Surveyaan V1 Ground Control Software in your Android mobile from play store. Open the application. If you are the first time user, you need to register yourself and your aircraft serial number with Surveyaan V1. To register yourself with Surveyaan V1, click on the register button available in footer of app login screen.

After clicking on the register button, you are re-directed to the app.surveyaan.com. You need to select the register tab and completely fill the registration form and submit. Make sure to enter the aircraft serial number in

the drone ID field of the form as shown below:

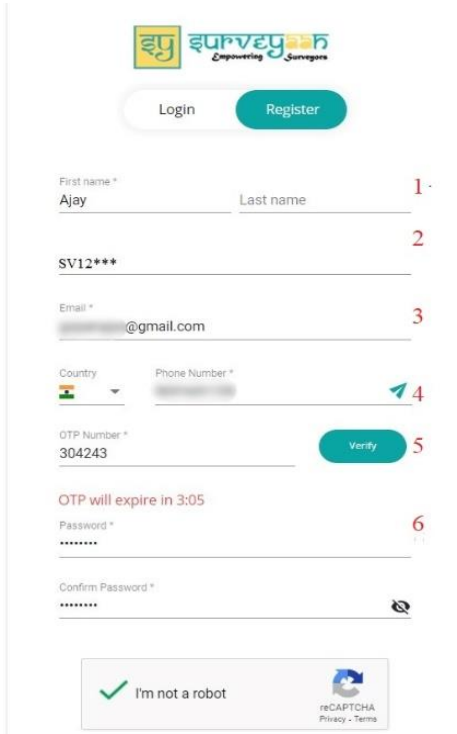

The screenshot shows the registration page with the following fields and callouts:

- 1:** First name and Last name fields. The first name field contains "Ajay".
- 2:** Drone ID field (SV12***).
- 3:** Email field (containing @gmail.com).
- 4:** Country and Phone Number fields. The country is set to India.
- 5:** OTP Number field (containing 304243) with a "Verify" button.
- 6:** Password and Confirm Password fields.

At the bottom, there is a reCAPTCHA "I'm not a robot" checkbox and a "Verify" button.

Figure 5: Surveyaan V1 Login/Registration Page

1. First and Last Name: Enter your First name and Last name.

2. Drone ID: Enter Drone ID of the Surveyaan V1. You may find the Drone ID at the back of the aircraft or back of the Ground control station.

3. Email Address: Enter your email address.

4. Phone Number: Enter the phone number and click on the button next to it to get the OTP.

5. OTP Number: Enter the OTP here received on your registered mobile number.

6. Password: Must be at least contain 6 characters.

After filling all the fields, check the CAPTCHA and click on the Submit button. A verification mail will be sent to your registered mail account. Open your mail account, find the verification mail link and click on the link to get your account verified and click on continue.

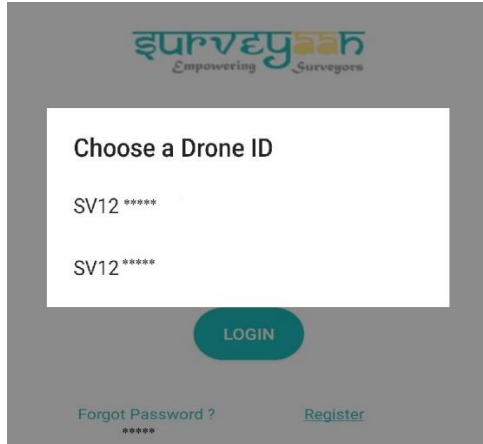

Now you are successfully registered. Open the App again, enter your credentials and click on the Login button. Now select the registered drone id from this window.

Note: User need to select a Drone ID to start operating the aircraft

After selecting the aircraft ID, you reach a page if the control app is not connected to the Ground Unit where you can test your KML or load map in the background of the location where you are going to fly.

The options available in this page are:



- 1. Last Location:** This will give the last location (coordinates) of the aircraft if the communication gets lost.
- 2. Info:** This tab shows if the drone is not connected, if the drone is connected it was hide itself.
- 3. Drone Id:** It shows the id of the drone that is connected to the current logged in account.
- 4. App Version:** It shows the current app version.
- 5. Wi-Fi:** Using this Wi-Fi button we can click on it and connect to the communication box.
- 6. Logout:** Account will get logged out from the device.

6. Flight Procedures

6.1 Assemble the Aircraft

Below is a detail procedure to assemble the aircraft.

6.1.1 Mounting the Propeller

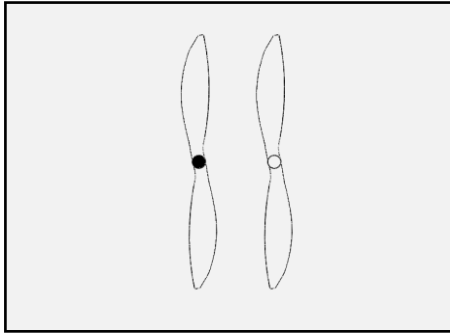

There are two sets of propellers that have been provided. One pair with silver marking and other with black marking. Silver marked propellers will be mounted on silver color marked motors and the black ones will be mounted on black marked motors.

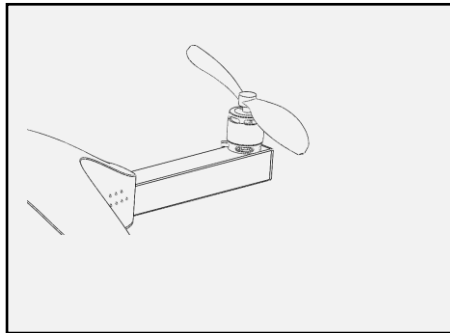

Place the propeller on the mounting shaft of the motor and then rotate. The silver marked propellers should be rotated in clock wise direction whereas black marked propellers should be rotated in counter clock wise direction.

Note: Check that all the propellers are secure before each flight

6.1.2 Mounting the Camera

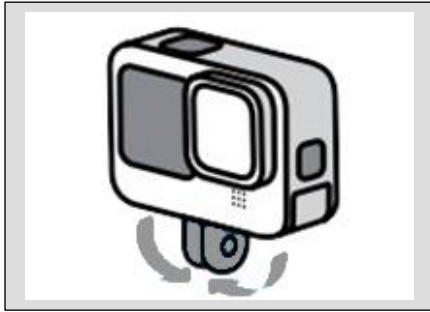

Flip the folding fingers down into the mounting position.



Interlock the folding fingers on your camera with the mounting fingers on the buckle.

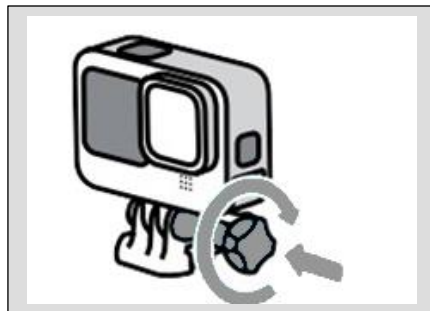

Secure your camera to the mounting buckle with a thumb screw.

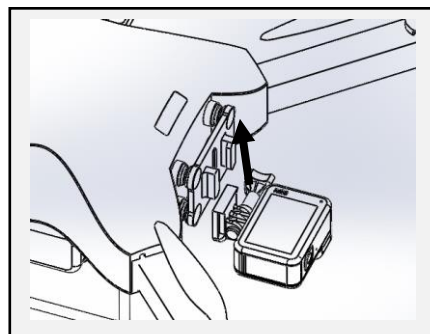

Pull the rubber lock out and slide the camera on the camera mount provided on the aircraft and then push the rubber lock back.

Note: Make sure that the camera is fully charged, and SD card is properly inserted before the flight. Make sure that the camera is facing towards the ground and is properly tighten to the aircraft.

6.1.3 Mounting the Antenna

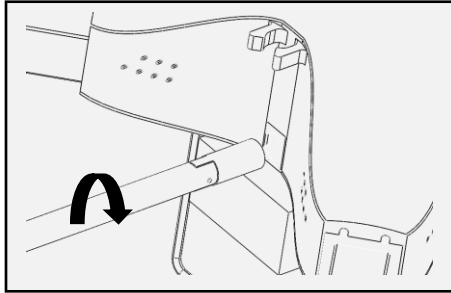

Rotate the antenna clockwise on the SMA connector provided on the body of the aircraft.

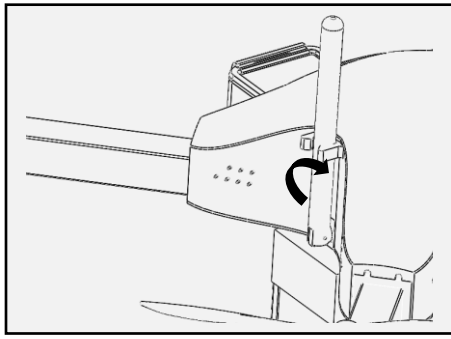

Bend the antenna and fix it with the body.

6.1.4 Mounting the Aircraft Lithium Ion Battery

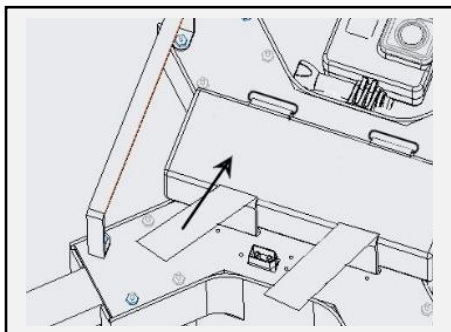

Open the battery strap and insert the battery into the strap.

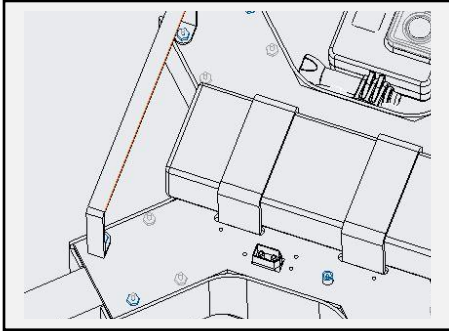

Once the battery has been inserted, tighten the strap.

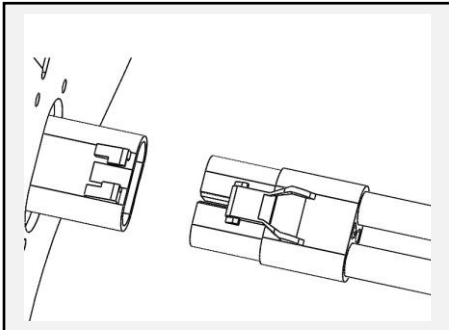

Insert the battery's power port into aircraft's power port. Make sure the mating of connectors are correct when inserting the power cable.

6.1.5 Preparing the Ground Unit

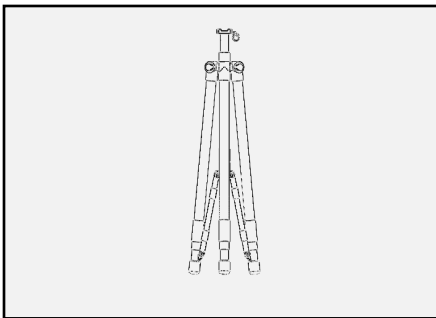

Unfold the tripod and place it on level ground.

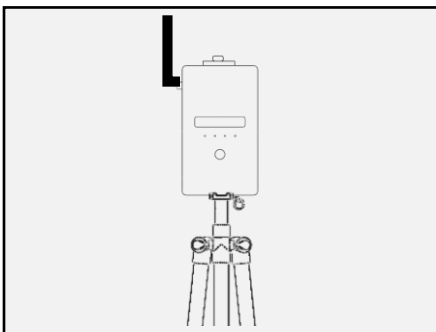

Mount the Ground Unit on tripod and screw the antenna on the Ground Unit as shown.

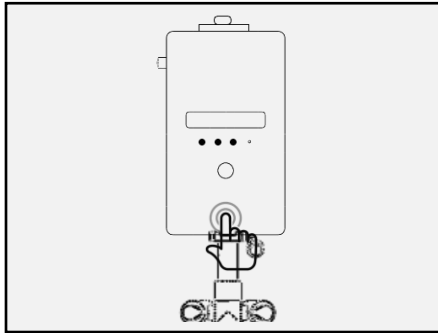

Long press (for more than three seconds) the power button provided on Ground Unit. Four blue lights will start glowing in a particular pattern. This confirms that the Ground Unit has been powered on.

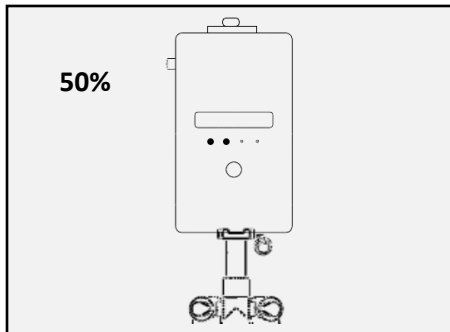

Wait for a few more seconds and lights will start blinking. Number of lights shows the charge percentage of Ground Unit. For example, two out of four LEDs are glowing in the shown picture. So the charge percentage of Ground Unit is 25-50%.

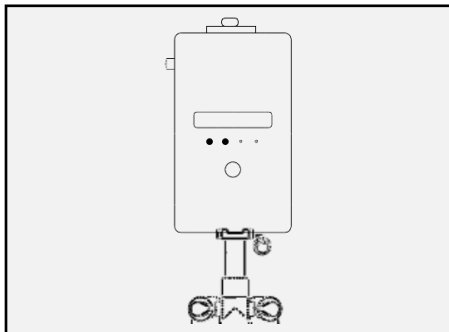

Connect the mobile phone with the Wi-Fi generated by the Ground Unit. The SSID of Ground Unit Wi-Fi is same as the serial number of the aircraft and password is **@surveyaanWifi**. If the mobile gets successfully connected, blinking lights will become solid.

Note: Make sure the tripod is at least 5 to 10 meters away from the aircraft and the Ground Unit is fully charged before the flight.

6.1.6 Camera in Pairing Mode

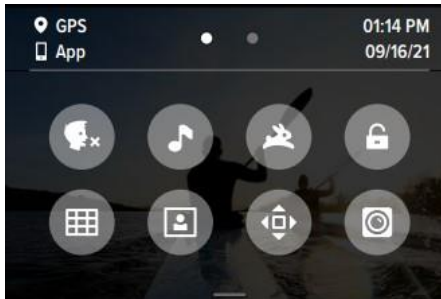

If your camera is not already powered ON, press power button on the camera situated at right hand side of the camera. With your camera in landscape orientation, swipe down on the rear screen to access the Dashboard.

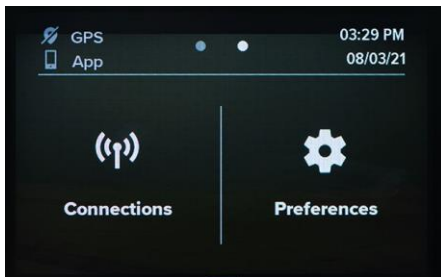

Swipe left and tap Preferences > Connections > Camera Info. Note down the last four digit of Camera Name.



Tap on the back screen. You should be now in Connections Section. Go to Connect Device and tap on the GoPro Quik App. The camera is in pairing mode now.

6.2 Connect Surveyaan V1 Ground Control App

If Ground Control App is already connected to Ground Unit as explained in last step of Ground Unit preparation section and four navigational lights of aircraft are blinking at 1Hz, you should directly get a camera connection screen on the app as shown in figure below. If Ground Unit Wi-Fi is not connected, follow the

Ground Unit preparation steps again and then open the ground control app again.

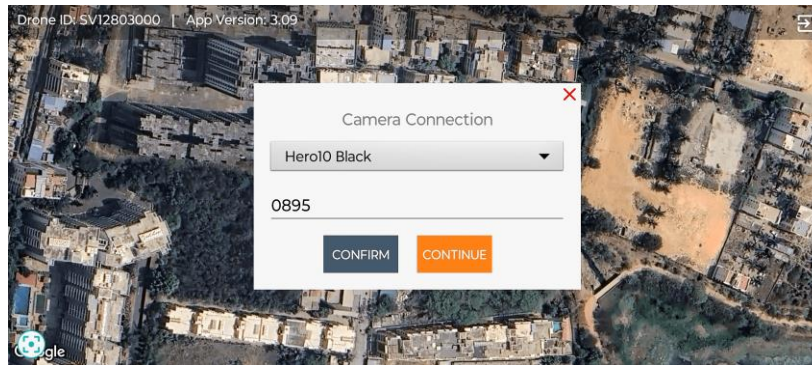

Enter the last four digit of camera serial number and click confirm. It is assumed that you know the camera serial number if not please see camera pairing section of this document.

After the camera gets successfully connected you reach this page. The options available in this page are:

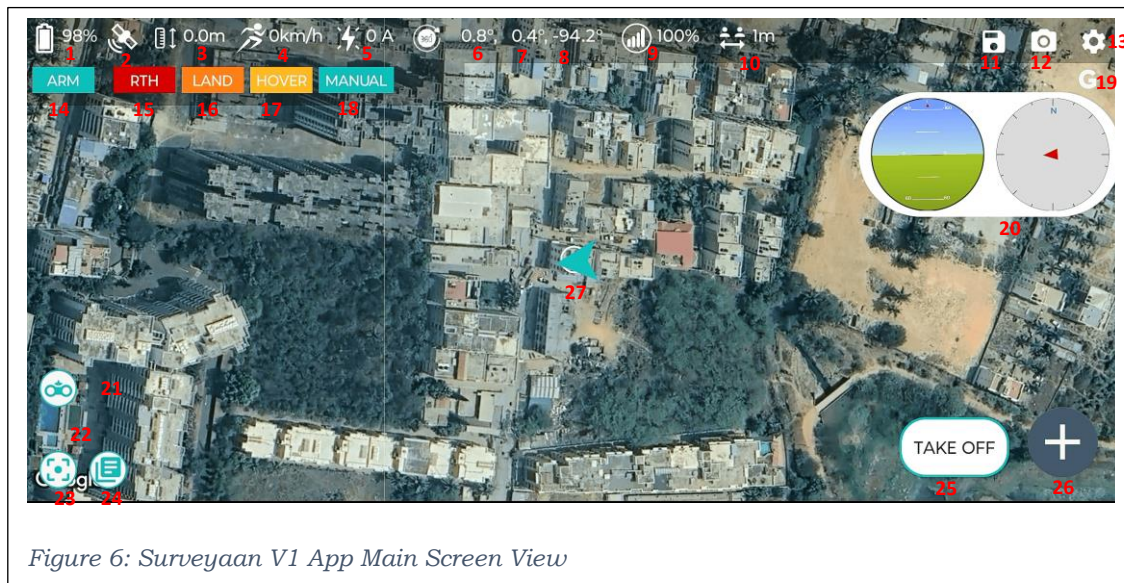

Figure 6: Surveyaan V1 App Main Screen View

1. **Aircraft Battery:** This will indicate the battery percentage of the aircraft.
2. **GPS:** This will indicate the GPS signal. If GPS signal is weak it will be shown in red and white color indicates good signal.
3. **Altitude:** The aircraft's current altitude will be shown here.

- 4. Horizontal Speed:** This will show the aircraft's horizontal speed.
- 5. Current Drawn:** It shows the actual current utilized by the drone while flying
- 6. Roll:** It gives the live reading of the side - ways inclination of the drone.
- 7. Pitch:** It gives the live reading of the upward or downward tilt of the drone.
- 8. Yaw:** It gives the live reading of the rotation of the drone around the vertical axis.
- 9. Signal:** It gives the signal strength between the drone and the Ground Unit.
- 10. Drone Distance:** It display the map centre distance from the drone current location.
- 11. Save Mission:** It is used to save the mission. If you need to fly the aircraft at the same place periodically then you can save the mission.
- 12. Camera:** This option will take you to the camera connection window.
- 13. Settings:** This is where you can perform calibrations, change the settings of the aircraft download the logs.
- 14. ARM:** This option is used to arm the aircraft. Before each flight it is mandatory to arm the aircraft to check whether the propellers are attached properly & all motors are functioning.
- 15. RTH:** This option is given to call the aircraft back to its home in case of any emergencies while flying a mission.
- 16. LAND:** It is used to land the aircraft at its current position. The aircraft will land at the position where the option was triggered by keeping the position locked and will land on the ground.
- 17. Hover:** It is used to make the drone stationary at one point.
- 18. Manual:** It is used to control the drone manually.
- 19. Status:** It is used to show the drone current status.
 - a. G: Guided mode
 - b. L: Landing mode
 - c. R: RTL mode (Return to Launch mode)
 - d. M: Manual mode
- 20. Heads-Up Display (HUD):** HUD is a visual interface of the drone data that shows roll, pitch and yaw of the drone.
- 21. HUD Toggle Button:** It is a button to toggle the HUD.
- 22. Resume:** It helps to resume a partially completed mission.
- 23. Centre map:** This will show the current position on the center of the screen.
- 24. Notifications:** This is where you get messages like any errors or warnings during operations.

25. Take off: This is where you get messages like any errors or warnings during operations.

26. Create Mission: Here we can create missions. There are 3 types of missions.

27. Home Position: It gives the ground position from where the drone will takeoff.

6.3 Flights Mission

Click on create mission button and select the type of mission as shown in the figure below:

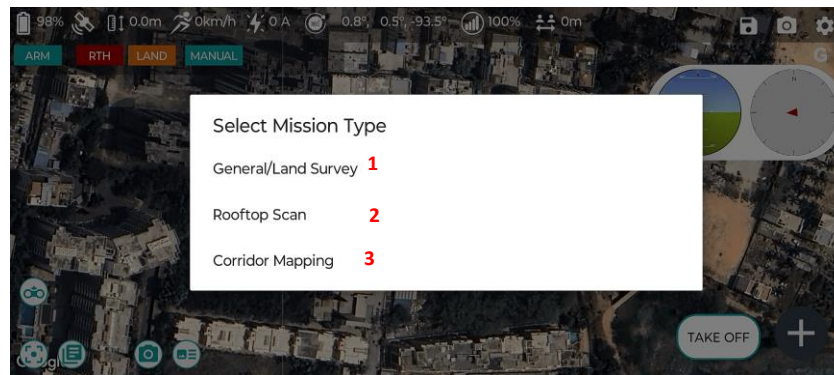

All three types of mission and their configuration options are explained in the below section. Users need to plan mission appropriately by looking at this guide.

There are three types of Missions:

1. General Land Survey
2. Rooftop Scan Mission
3. Corridor Mapping Mission

6.3.1 General/Land Survey Mission

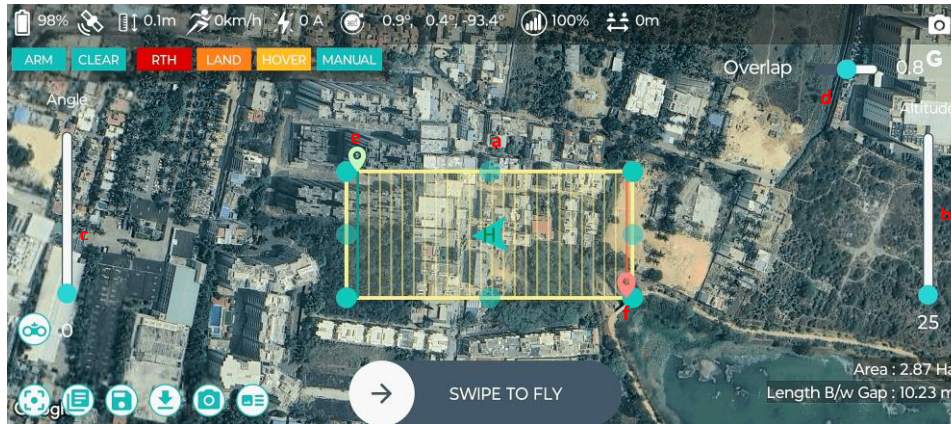

Figure 7: General/Land Survey Mission

- a. **Bubble Points:** These are bubble points which are used to move and draw the area where you want to fly the aircraft. Long pressing on any round blue point will activate the bubble point and we can move and release the finger to place the point.
- b. **Altitude:** This slider is used to set the altitude of the aircraft. Maximum altitude the aircraft can fly is 120m.
- c. **Angle:** Here we can select the angle at which you want the aircraft to fly this mission. Sliding the slider will move the lines inside the area to different angles.
- d. **Side-Overlap:** This will help the user select how much overlapping is needed between the photos. It encompasses the overlapping areas of photographs between adjacent flight lines. The range is from 0.7-0.9 and it is kept at 0.8 by default.
- e. **Green Pinpoint:** It denotes the location where the aircraft will fly first to start the mission.
- f. **Red Pinpoint:** It denotes the location where the aircraft will fly last and the aircraft returns to home position.

6.3.2 Types of Rooftop Scan Mission:

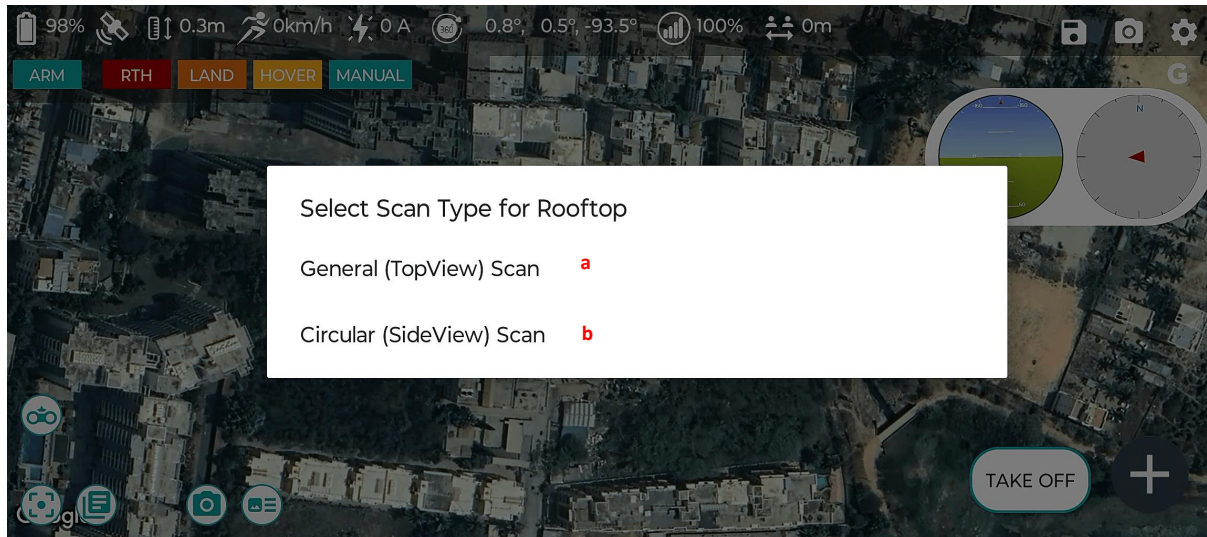
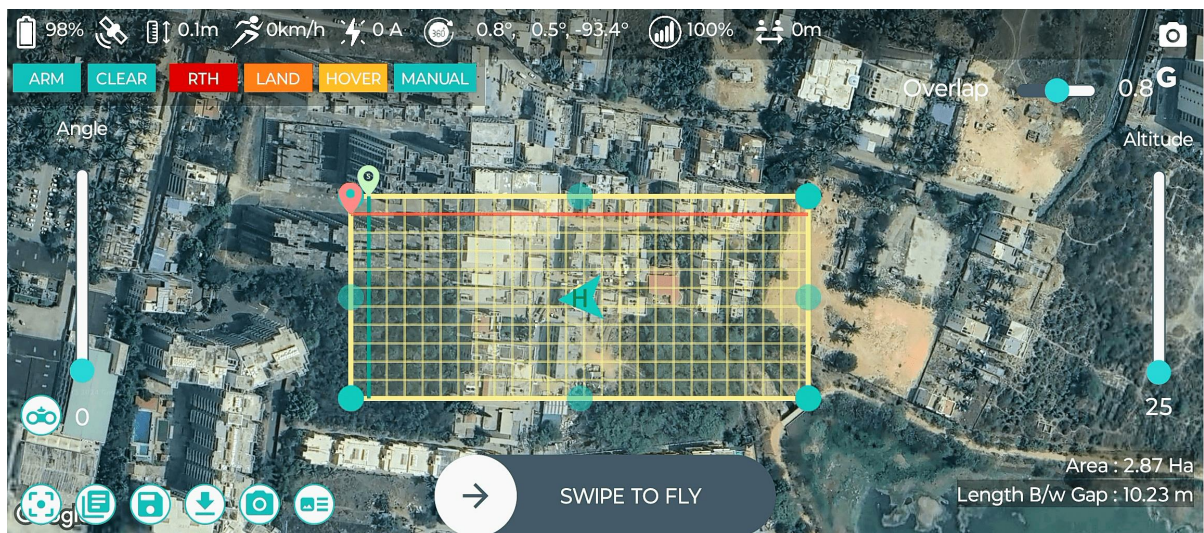

Figure 8: General Rooftop Scan Mission

a. Rooftop Scan Mission (General Scan)



Note: Here we have the same features as that of the general land survey except here the lines are in a grid format.

b. Rooftop Scan Mission (Circular Scan)

Figure 9: Circular Rooftop Scan

Note: In this type of mission, the camera is generally kept at 45 degree angle and the nose of the aircraft is always heading to the center of the rooftop. This is done so that we cover all the angles of the rooftop.

- i. **Rooftop Mapping Distance:** If you are flying from the rooftop then you can slide and keep your altitude here. This will calculate the altitude from the rooftop. The default altitude is at 25m. Here the horizontal and vertical distance will be the same.
- ii. **Ground to Rooftop Distance:** If you are flying from the ground then you can give the altitude with respect to the building.
 For Example, here we have set the Rooftop Mapping Distance to 25m and the Ground to Rooftop Distance to 0m then the aircraft will be flying at 25m from the rooftop and also the horizontal distance will be 25m.

6.3.3 Corridor Mapping Mission

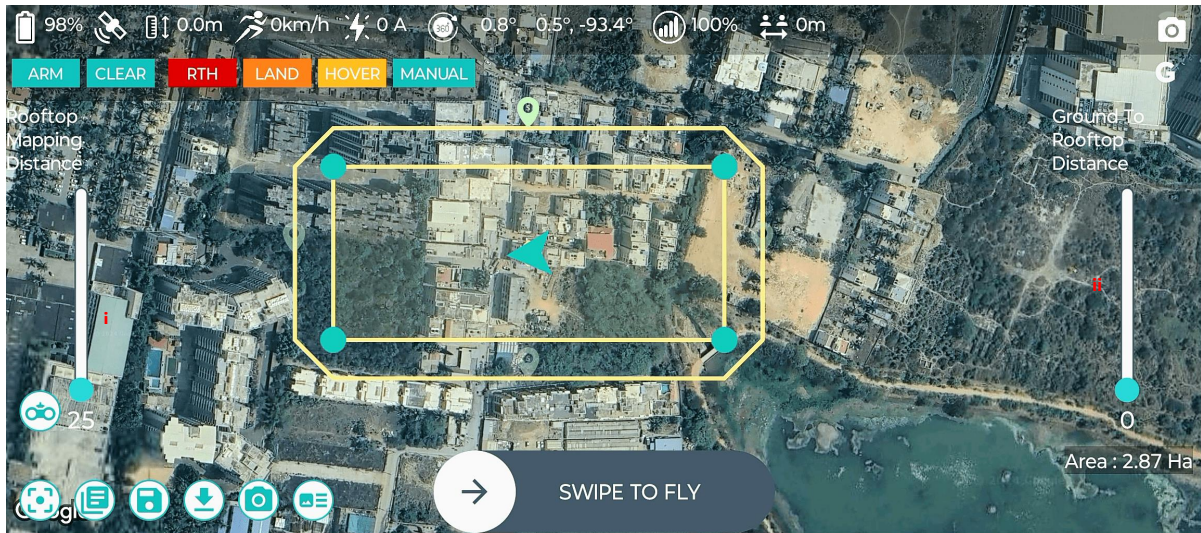
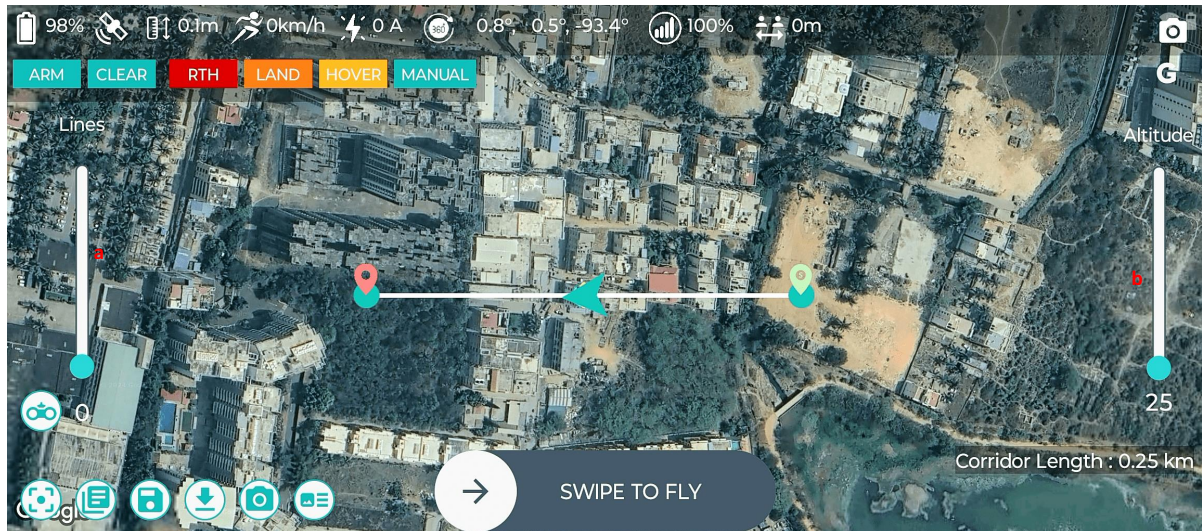

Figure 10: Corridor Mapping

- a. **Lines:** This will create lines and using these lines we can survey features like roads canals etc.
- b. **Altitude:** This slider is used to set the altitude of the aircraft. Maximum altitude the aircraft can fly is 120m.

Once the mission is planned successfully as explained above, swipe right on SWIPE TO FLY button in bottom. The aircraft will then automatically fly to the first point and then start its mission and after reaching the end point it returns back to the home position.

6.3.4 Resume Mission

If a previous mission is not completed and the aircraft returns to the home position with a low battery level, the mission can be resumed after the following steps are taken:

- 1. Swap the battery:** Replace the depleted battery with a fully charged one.
- 2. Connect the camera:** Ensure that the camera is properly connected to the aircraft.
- 3. Perform an arm check:** Verify that all systems are functioning correctly and perform the necessary pre-flight checks.

Once these steps are completed, you can proceed with resuming the previous mission. If the previous mission is not completed an play icon reflects on left bottom as shown below. After completing above steps press the resume icon to resume the mission.

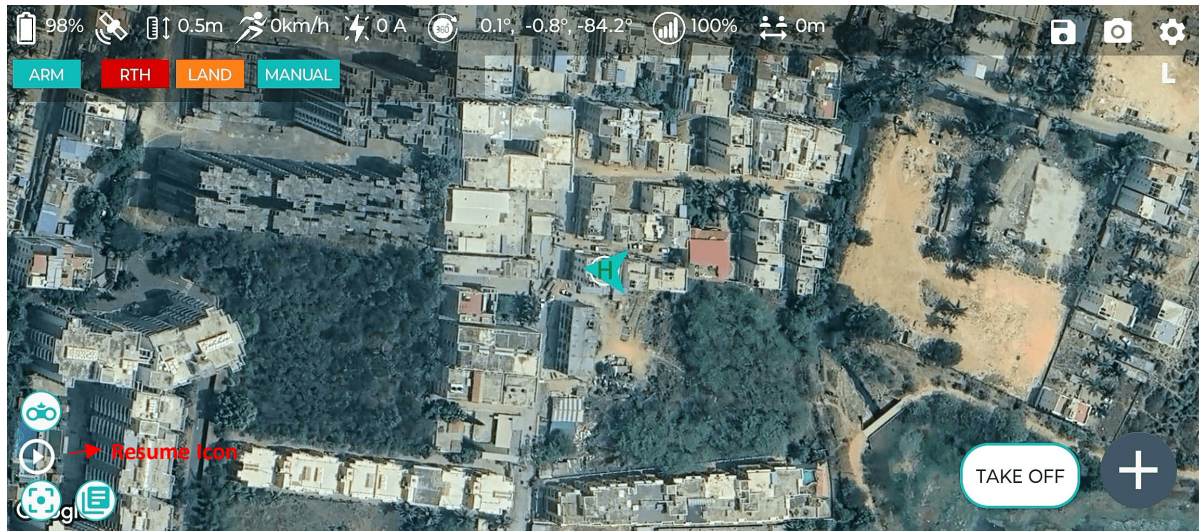
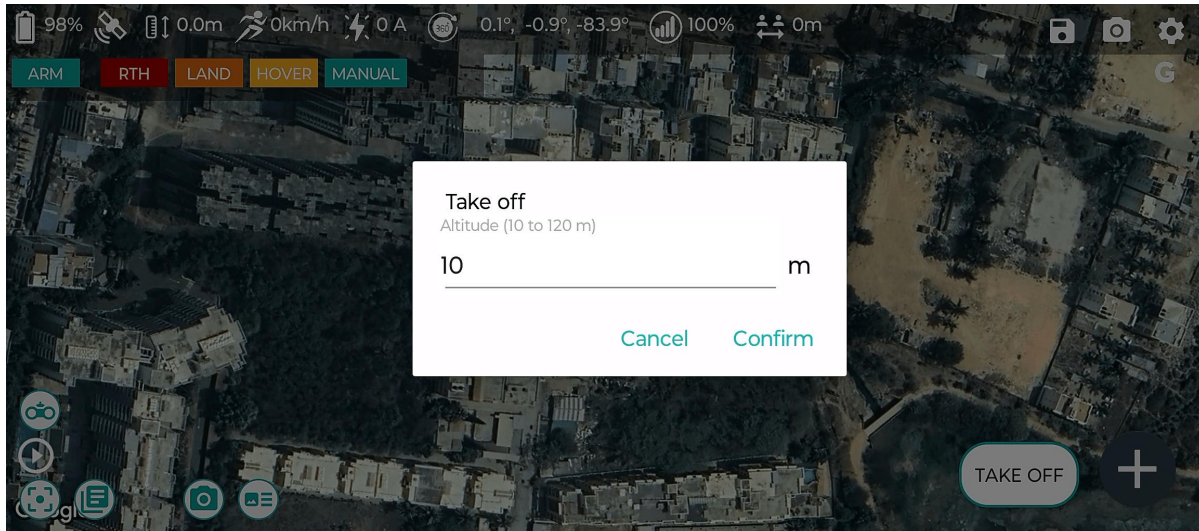

Figure 11: Resume Mission Icon

6.3.5 Take off



It allows the user to fly the drone in vertical direction. Arm the drone first. Click the TAKE OFF button, a prompt will appear to take the altitude input in meters. Altitude range is restricted to 10m – 120m. After entering the altitude click on confirm drone will start ascending/descending to that height.

6.4 Manual Control



Figure 12: Manual Control

Once the drone altitude is above 5m Manual control is enabled.

- 1. Left Thumbstick:** It is used to control throttle and yaw. Moving it up and down controls throttle and sideways movement gives yaw control.

2. **Right Thumbstick:** It is used to control roll and pitch. Up and down movement changes Pitch and sideways movement controls roll.
3. **HUD:** It is a visual interface. The left one shows roll and pitch and right one shows yaw like a compass.
4. **Status:** 'M' Shows it is in manual mode.
5. **Manual Button:** Button that gives access to manual control.

6.5 Aircraft Settings

It includes calibration of sensors like accelerometer, Compass, Gyro, geo-fence setting, Battery error message, Logs download & Logout.

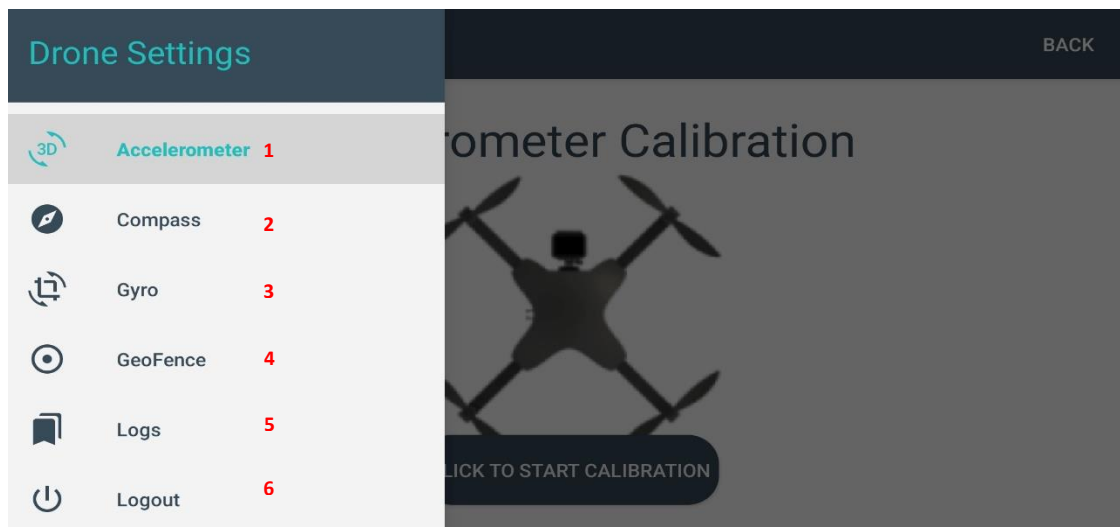

6.5.1 Accelerometer Calibration

This is where we calibrate accelerometer sensor. It is required when we get notifications like “*accels inconsistent*”. Before starting the sensor calibration make sure to remove the propeller. To calibrate accelerometer select first option from the settings side navigation.



Tap on **CLICK TO START CALIBRATION** button to start the calibration.

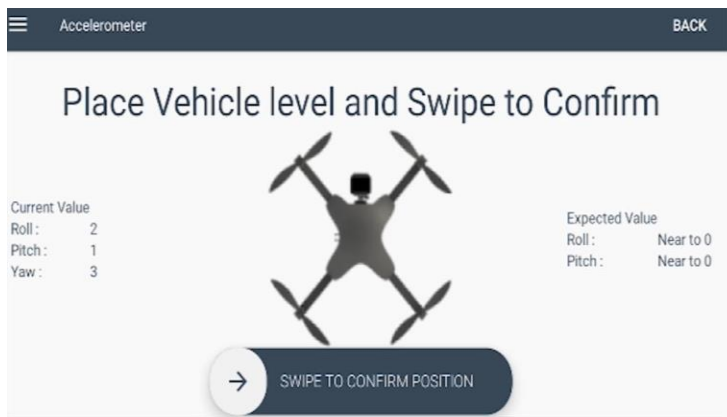

We have to keep the aircraft in a level surface and then swipe to confirm.

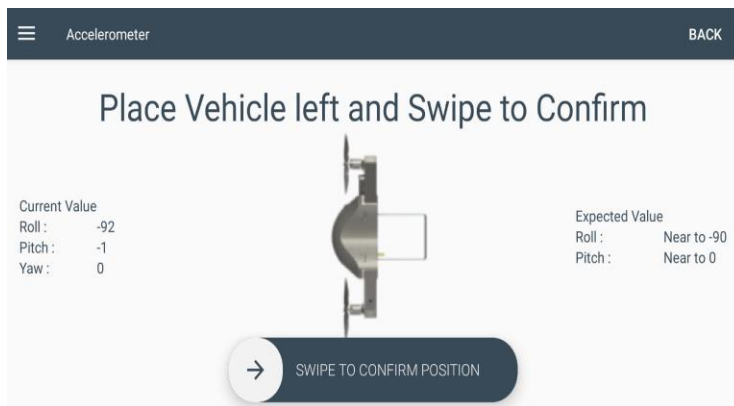

Then we have to keep the aircraft to the left (such that Antenna side face ground) and then match the current roll & pitch value to the expected roll & pitch value and then swipe to confirm. + or - 5 in the current roll & pitch value is acceptable.

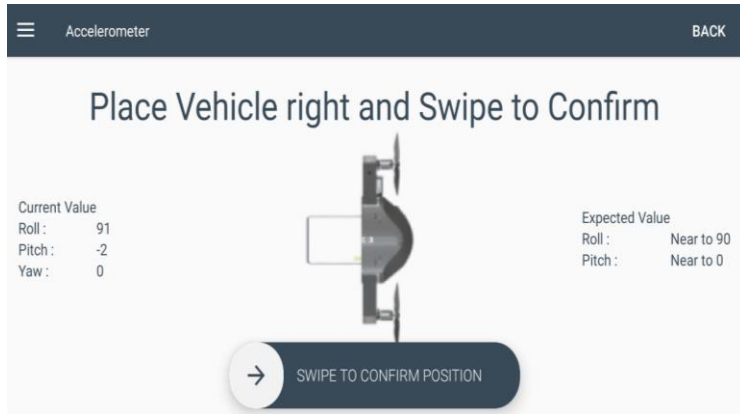

Then we have to keep the aircraft to the right ((opposite to the Antenna side)) and then match the current roll & pitch value to the expected roll & pitch value and then swipe to confirm. + or - 5 in the current roll & pitch value is acceptable.

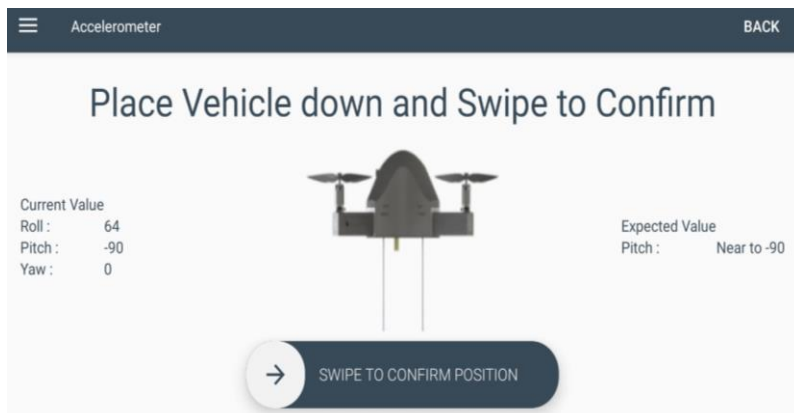

Then we have to keep the aircraft in nose down (camera side is pointed towards the ground) position and then match the current pitch value to the expected pitch value and then swipe to confirm. + or - 5 in the current pitch value is acceptable.

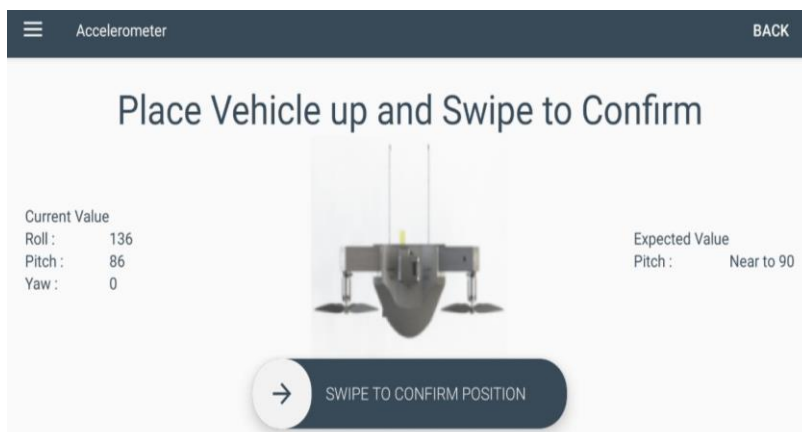

Then we have to keep the aircraft nose up (camera side is pointed towards the sky) position and then match the current pitch value to the expected pitch value and then swipe to confirm. + or - 5 in the current pitch value is acceptable.

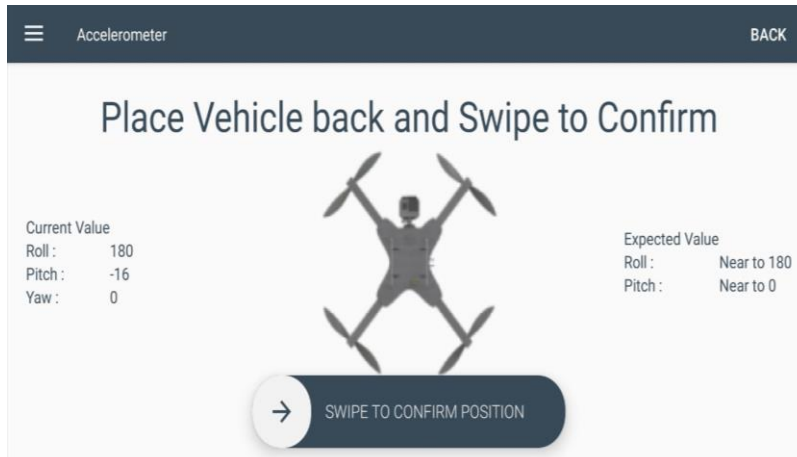

Then we have to keep the aircraft in a upside down position and then match the current roll & pitch value to the expected roll & pitch value and then swipe to confirm. + or - 5 in the current roll & pitch value is acceptable.



Figure 13: Accelerometer Calibration

Now you get a message displaying the accelerometer calibration has been successful and wait for 90 seconds for the aircraft to restart.

6.5.2 Compass Calibration

Similar to the accelerometer select second option to calibrate the compass. It consist dual compass. So, while calibrating readings will fluctuate.



This is where we calibrate compass sensors. It generally required when “*compass inconsistent*” comes as a notification before arming the aircraft. First, we need to select the Compass option from the settings and then it would ask to swipe to start calibration.



Then we have to start rotating the aircraft in all directions such that each face of the aircraft faces ground at some point of time until the bar reaches 100%.

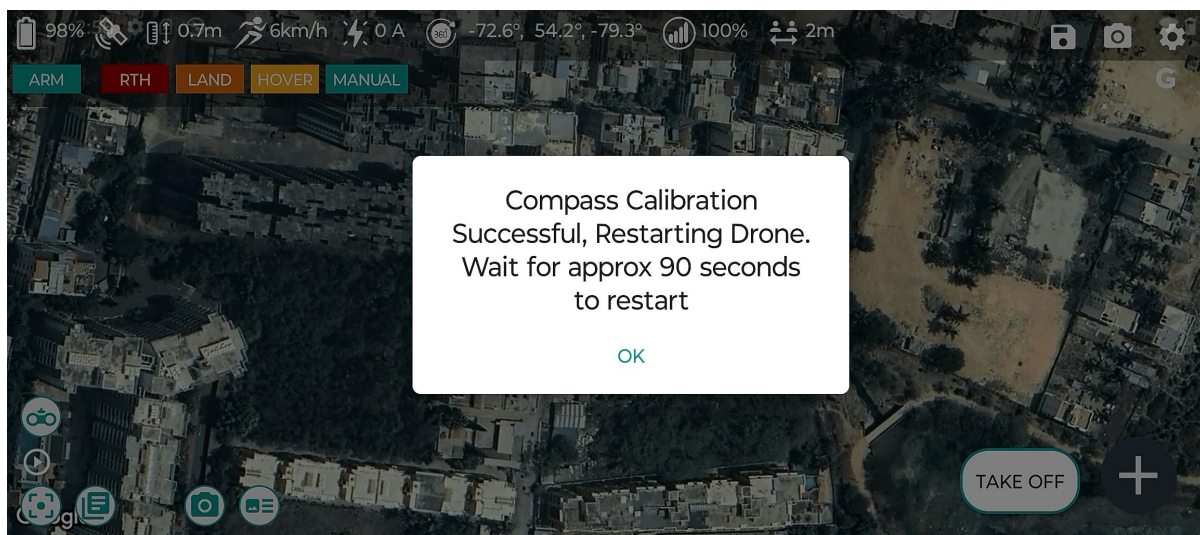
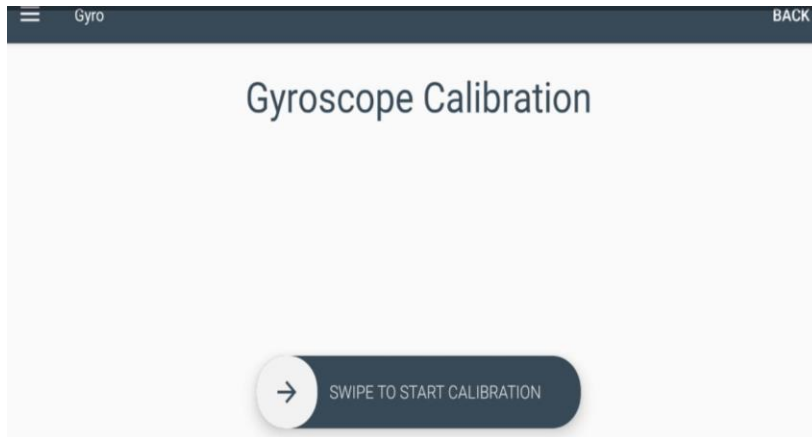

Figure 14: Compass Calibration

And after the bar reaches 100% you get a message displaying the compass calibration has been successful and wait for 90 seconds for the aircraft to restart.

6.5.3 Gyro Calibration



This is where we calibrate Gyroscope sensors. First, we need to select the Gyro option from the settings and then keep the aircraft on a levelled surface and then swipe right to start calibration and it would get calibrated successfully.

6.5.4 Geo-fence Setting

Radially Surveyaan V1 path can be planned inside the radius of 1.5km from the home location. It means path can be planned only inside this radius. If any point of the planned path is outside this boundary aircraft won't fly and throws error in the Surveyaan V1 Ground Control app.

By default, geo-fence is set at 1.5 Km radially and 120m in altitude. It can be customized to change the geo-fence less than 1.5 km up to 50m radially and less than 120m in altitude up to 10m.

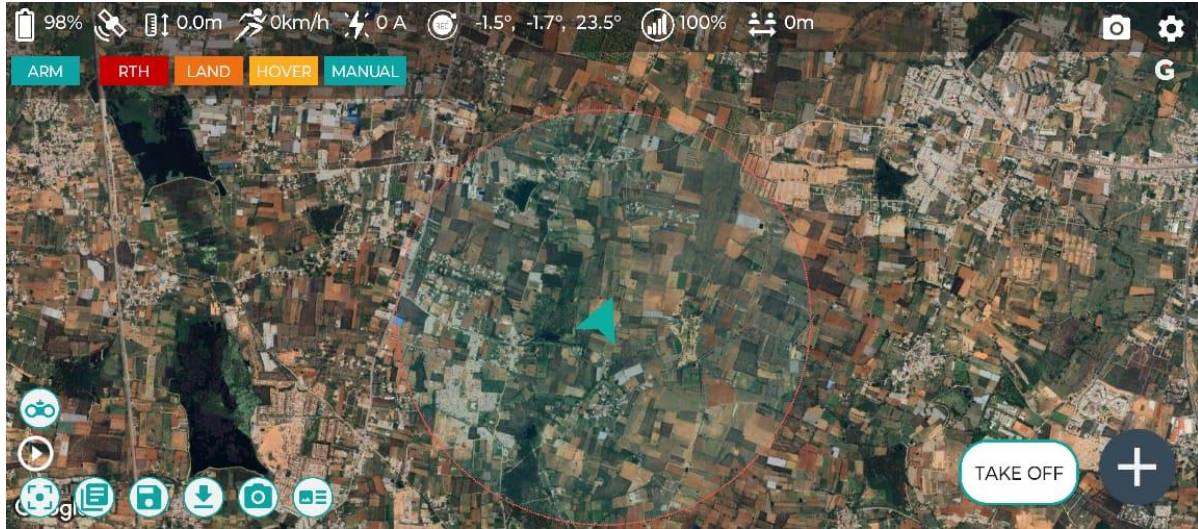

Red dotted lines shows the maximum geo-fence limit (1.5km radius). Beyond this, path cannot be planned

Geo-fence range can be changed to any value less than 1.5 km up to 50m and altitude can be changed to any value less than 120 up to 10m from the Geo-fence setting as shown below. Here fencing is set at 534 m radially from the home position.



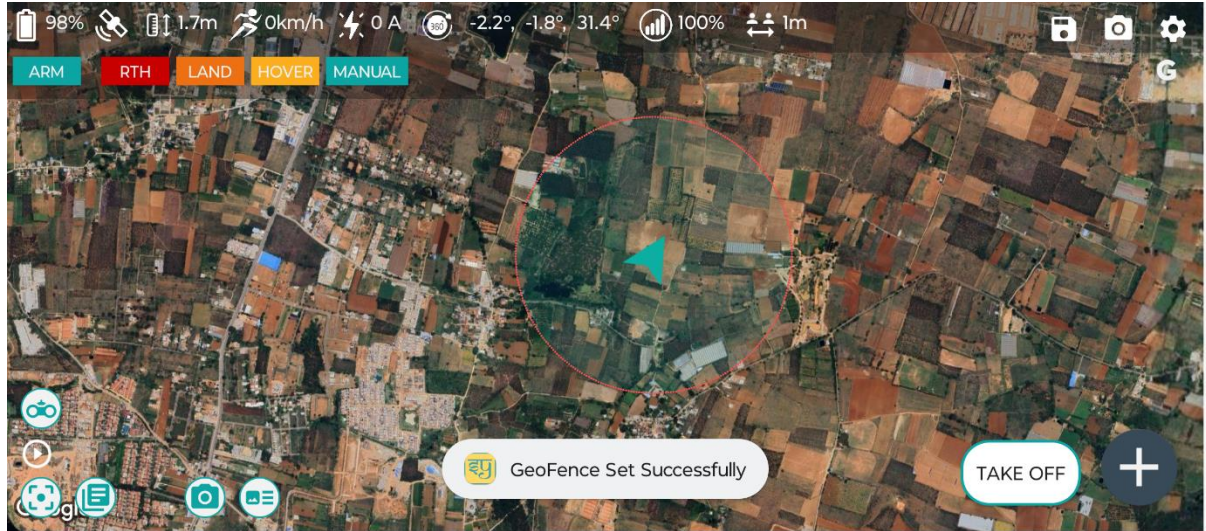

Geo-fence is set at 534 m, shown as red dotted lines in the Control app.

Geo-fence breach

If path planned is outside this fence, then user won't be able to fly the aircraft & an error message will flash in control app mentioning geo-fence breach.

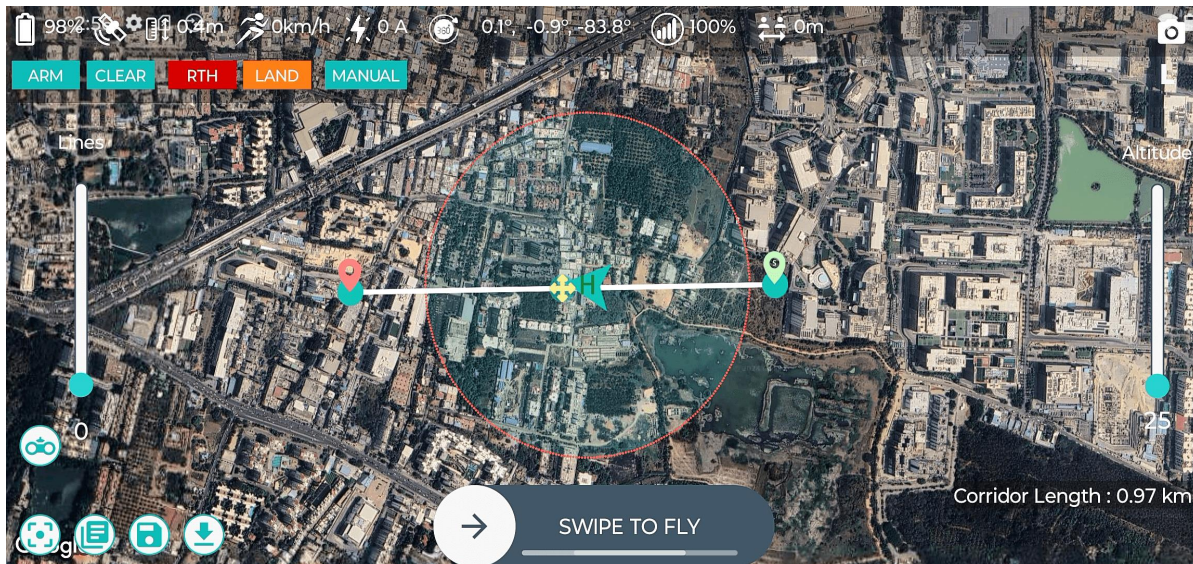

Path planned is outside the geo-fence area

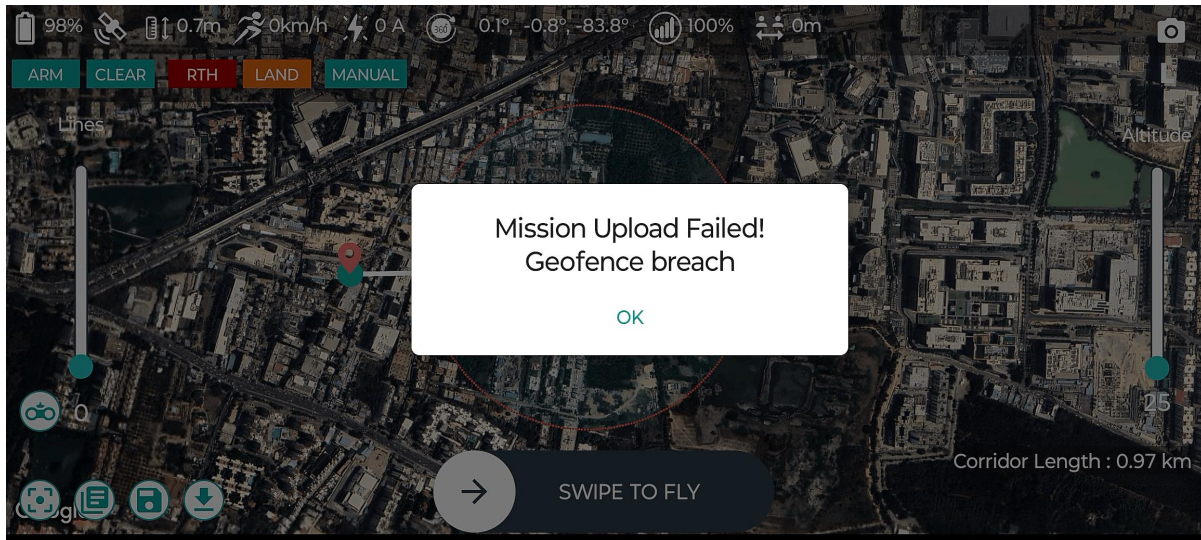

Mission failed due to geo-fence breach

6.5.5 Logs

For every flight, logs are generated inside the vehicle that include necessary information related to the flight. These logs can be downloaded from here. To download the logs, please follow the procedure outlined below.

1. Locate the “Logs” tab under setting in the control app. Swipe the “SWIPE To Connect WiFi” button to the right side.

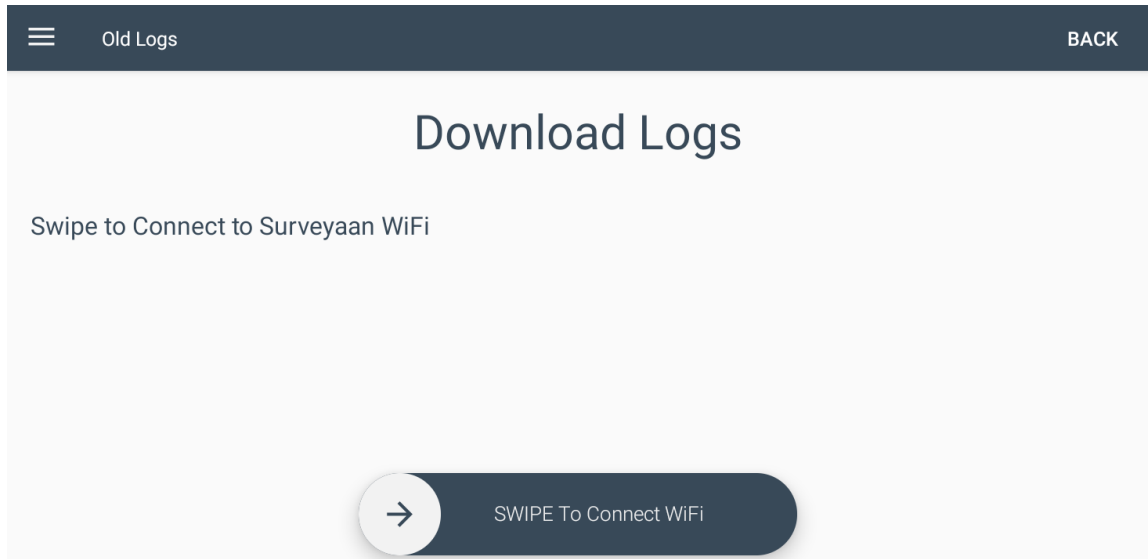

It allows aircraft to connect to the Ground control station Wi-Fi to which control app is already connected & it shares the logs folder on a dynamic IP address as visible in app below. Connect your windows/Linux based system to the Ground control station Wi-Fi.

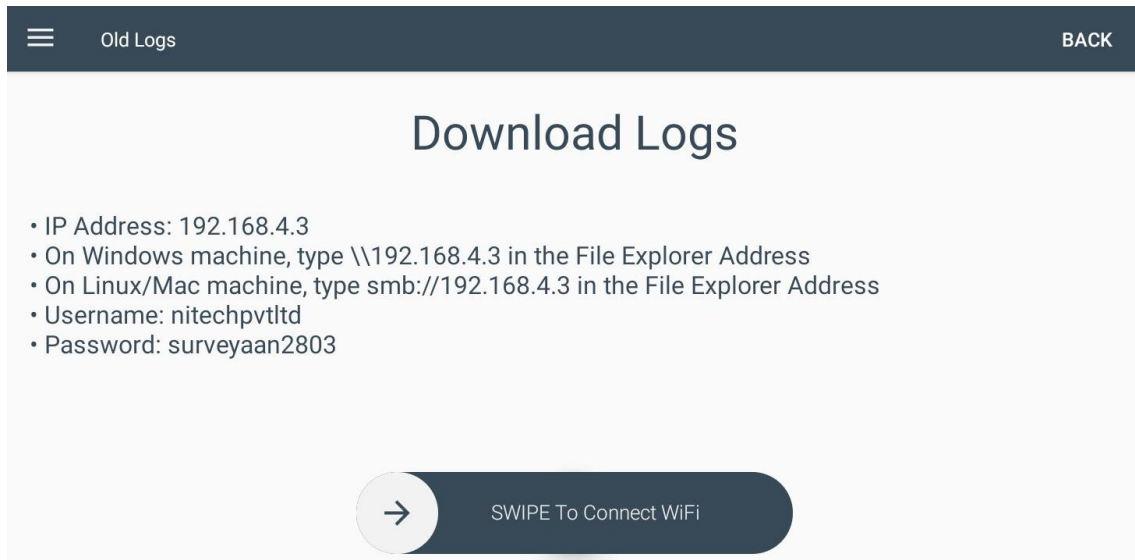

Based upon the system (windows/Linux) follow the procedure as mentioned in the above image and you will have the access to the Logs. Log folder will be shown with name “Surveyaan-Logs”.

Once you will have the access to logs you can copy and keep it in your local system.

6.5.6 Logout

The logout options let you logout from the application.

6.6 Aircraft landing and repacking everything

Aircraft Landing and Repacking Procedure:

1. After the aircraft has landed on the ground, ensure that you wait for the propellers to stop rotating before proceeding.
2. The landing process will be considered complete when you receive a visual completion signal on the control application.

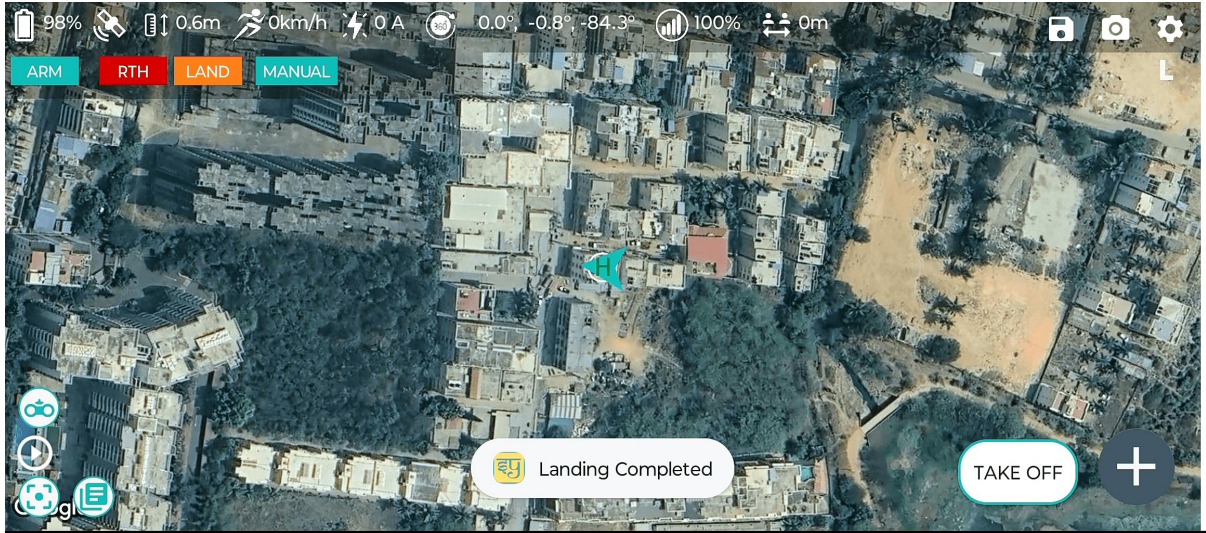

3. Once the landing is confirmed, disconnect the power terminal.
4. Remove the battery and camera from the aircraft. Loosen the propellers and antenna.
5. Loosen the ground station antenna, fold the tripod, and carefully pack them back into the box.
6. Ensure that all parts, including the aircraft, have been securely placed inside the box.
7. Finally, close the box, ensuring it is properly sealed.

6.7 Preflight checklist

1. Ensure that all four status lights are continuously blinking.
2. Confirm that the micro SD card is inserted in the camera and securely attached to the aircraft.
3. Check that the camera lens is clean and properly oriented towards the ground.
4. Verify that the battery is securely fastened with the straps and is fully charged.

5. Prior to flight, use the control app to check the motors and ensure there are no unusual noises when they rotate.
6. Inspect the propellers to ensure they are securely tightened.
7. Remember to attach the antenna before flight and ensure it is securely fastened.
8. Check the control app for any errors related to accelerometer, compass, or gyroscope sensors. Perform necessary calibration if needed.
9. Ensure the ground station battery is fully charged before the flight.
10. Fly only in open areas, ensuring that the flight path is clear of obstacles.

6.8 Post flight routine

1. Battery Care:

Allow the battery to cool down before charging. Avoid overcharging or depleting the battery too much.

2. Camera Cleaning:

Gently clean the camera lens and sensors with appropriate cleaning tools to remove dirt, fingerprints, and debris.

6.9 Continuous Flight Monitoring

Keep an eye for the messages that appears on the apps. If any unusual message appears then abort the mission.

6.10 Failsafe and Emergency contingencies

The aircraft is equipped with failsafe mechanisms that trigger the following actions:

1. C2 Data Link Loss: In the event of communication loss for more than 20 seconds, which is a rare occurrence, the aircraft will initiate a return to launch (RTL) operation.

2. Battery Failsafe: When the aircraft's battery percentage drops below 28% within a 700-meter radius from the home location, or below 32% outside the 700-meter radius, the aircraft will automatically return to its home location.

3. Geo-fence Breach: In case geo-fence is breached the aircraft will trigger RTL, and drone will return to its takeoff location.

4. Camera Disconnection: If the camera loses connection with the aircraft due to low battery, the aircraft will initiate a return to launch (RTL) operation.

If a mission is planned incorrectly and the aircraft is already in flight, the operator can press the RTH button to recall the aircraft to its takeoff location.

In the case of heavy rain or strong winds, it is at the operator's discretion to decide whether to initiate a return to launch (RTL) by pressing the RTH button or to immediately land the aircraft in its current position by pressing the Land button.

In the event of a permanent loss of GPS signal, the aircraft will automatically switch to Land mode.

7. Data Link

7.1 Description & Specification

Surveyaan V1 uses **Digi XBee3 PRO** as C2 Data link communication to communicate between the drone and the Ground Unit. It uses Xbee as a networking protocol for point-to-point networking. It is responsible for managing and controlling the drone.

There are two Data link module, one is installed on the drone, and the other is installed on the Ground Unit acting as an end device. The devices require minimal power to provide reliable delivery of data. The devices operate within the ISM 2.4 GHz frequency band. For the optimal use of the device, a 2.4 GHz 3.2 dBi RP-SMA Male Omni antenna is connected at each side.

Also, while communicating both devices use the AES 128-bit encryption for safe transmission.

Specification of communicating modules:

Specification	Digi XBee3 PRO
Trans receiver Chipset	Silicon Labs EFR32MG SoC
Supply voltage	2.1-3.6 V
Transmit Current	135 mA
Transmit Power output (software selectable)	+19 dBm
RF data rate	RF 250 Kbps, serial up to 1Mbps
Receiver Sensitivity	-101 dBm
Frequency Band	ISM 2.4 GHz
Operating temperature	-40 to 85 °C (industrial)
Antenna options	RPSMA Connector
Protocol	Xbee
Encryption	128/256 bit AES
Channels	16

Table 5: Communication Module Specification

Specification of Antenna:

Specification	Value
Frequency range	2.4 GHz
Antenna type	Whip, tilt
Number of bands	1
Antenna connector	RP SMA Male
Gain	3.2 dBi
Direction	Omni-directional
Body material	Plastic and Rubber

Table 6: Antenna Specification

7.2 Full Functioning

The C2 data link is a two-way communication link between an unmanned aerial vehicle (UAV) and its ground unit. It is used to transmit commands from the ground unit to the UAV, and to receive telemetry data from the UAV. The C2 data link is essential for the safe and efficient operation of a UAV.

Surveyaan V1 uses XBee3 PRO as its C2 data link. It is a line-of-sight (LOS) type of RF link, which means that the UAV and the ground unit must be in direct line of sight with each other for proper communication.

There are two XBee modules used in the overall system. One is mounted on the UAV (acting as the transmitter), and the other is in the Ground Unit (acting as the receiver).

The UAV's transmitter sends commands to the ground unit, and the ground unit's receiver receives those commands. The ground unit's receiver also sends telemetry data to the UAV's transmitter. The telemetry data includes information such as the UAV's location, altitude, speed, and other parameters.

7.3 Visual & Aural Alert on Communication Loss

To have proper communication between the unmanned aerial vehicles (UAV) and the Ground Unit there should not be any obstruction between the UAV and the Ground Unit, and the area should be free of interference. Apart from these two reasons, there could be a few other reasons as well due to which communication could get lost, such as damage to the Ground Unit, Ground Unit battery discharge, or damage to the antenna connected.

In all these cases, the pilot will get a visual and aural alert on the Surveyaan V1 Ground Control App saying "Communication Lost."

Communication loss can sometimes occur between the unmanned aerial vehicle (UAV) and the Ground Unit for a very short duration. This can happen due to a sudden orientation change or some minor obstruction between the UAV and the Ground Unit. But if communication is lost for more than 20 seconds, then only control app will alert the user and the drone returns to its home position.

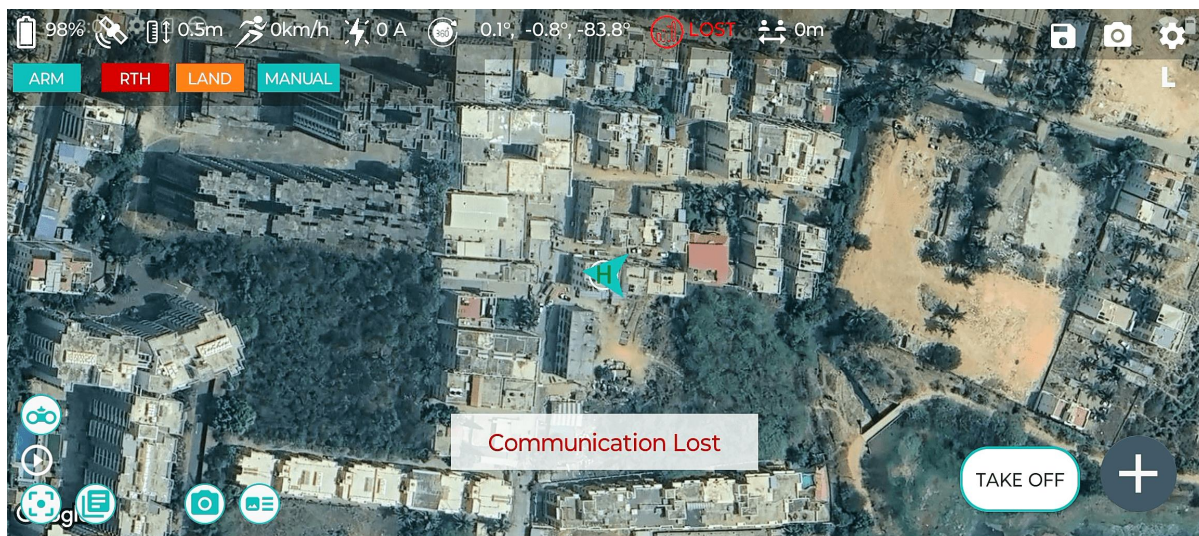

Figure 15: Communication Lost Message

If communication gets back again then also pilot will get aural and visual alert mentioning "Communication regained" and the pilot can track all the parameters again in the control app.

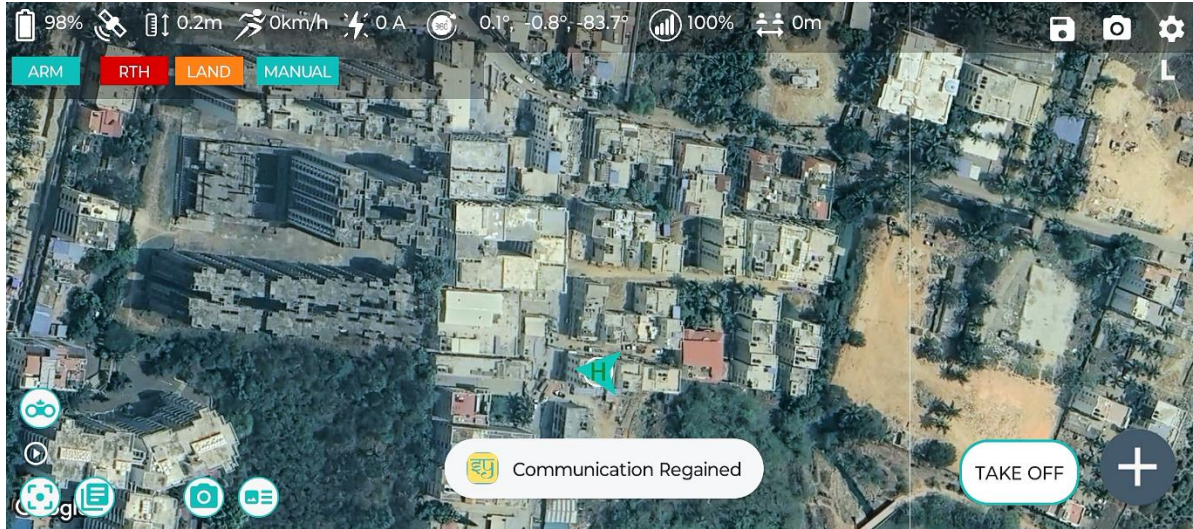
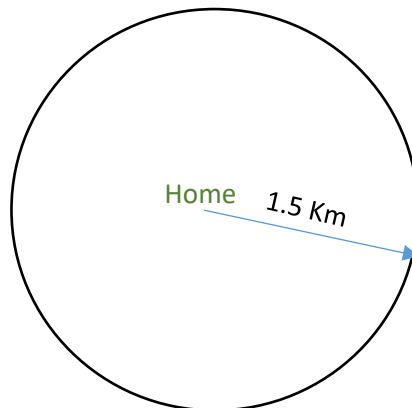

Figure 16: Communication Regained Message

7.4 Communication Range

Surveyaan V1 can communicate with its ground station up to 1.5 km radially in the outdoor RF line-of-sight range. So, being in a radius of 1.5 km and the clear line-of-sight ground station will have a permanent connection with the UAV.

While the UAV is in mission pilot will have full control to pause the mission, take manual control & trigger RTL (Return-to-Launch) command.



7.5 Data link Loss Strategy and Other Contingencies

There are three contingencies available and the drone executes RTL in all three cases.

1. Data link loss for more than 20 seconds.
2. Whenever the battery failsafe triggers.
3. If the geo-fence is breached by vehicle.

7.5.1 Data link loss strategy

Data link loss can occur due to variety of reasons, such as signal interference, environmental obstacles, or improper connection of antenna.

Momentary loss could also happen if the drone is just above the ground unit. To prevent that ground unit antenna could be oriented in such a way that it is 90 degree aligned to the drone antenna. In case the communication is lost for more than 20 seconds, the drone triggers RTL and returns to its takeoff location.

7.5.2 Battery Failsafe

When the aircraft's battery level falls to 28% within a 700-meter radius from the home location, or drops to 32% outside this radius, the battery failsafe mechanism will be activated. Consequently, the aircraft will automatically initiate a return to its home location.

7.5.3 Geo-fence Breach

In autonomous mode the drone does not breach the geo-fence. It means if user has given a waypoint outside the geo-fence, user won't be able to upload the mission to the drone.

In MANUAL mode, the drone automatically initiates a Return to Launch (RTL) procedure upon breaching the predefined geo-fence.

8. Life of Drone

Knowing how long each component in a drone system last is crucial for proper maintenance. The lifespan and performance of each part play a big role in how reliable and successful the drone is in operation. Understanding the life cycle of these components helps operators plan maintenance in advance. It's important to note that the life expectancy mentioned below is calculated for Surveyaan V1 under normal operating conditions.

Airframe life	40,000 hrs.
Battery Lifecycle	227 cycles
Propeller Life	258 hrs.
Permissible landings	10,000 landings
Motor life	258 hrs.

9. User Removable Nuts and Bolts

Surveyaan V1's airframe consists of several primary structural elements, and the failure of these parts can lead to significant deformation of the airframe structure. Following are the PSEs:

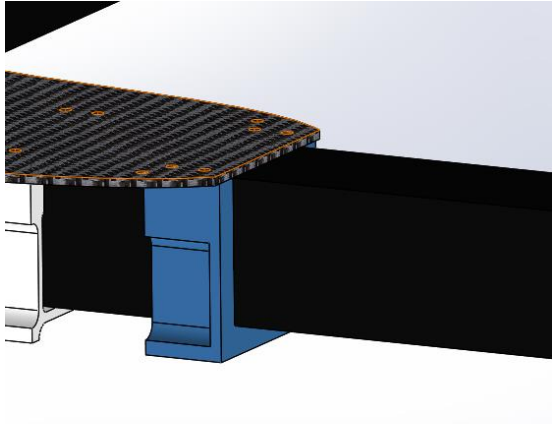
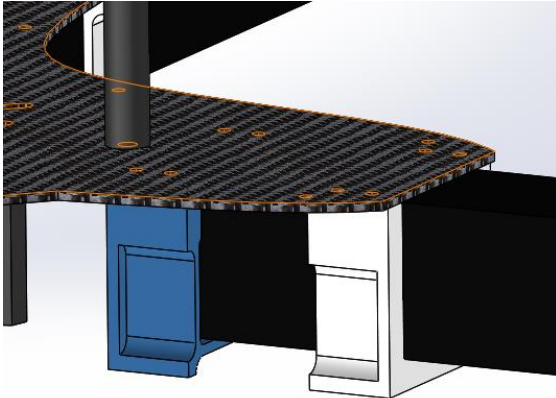
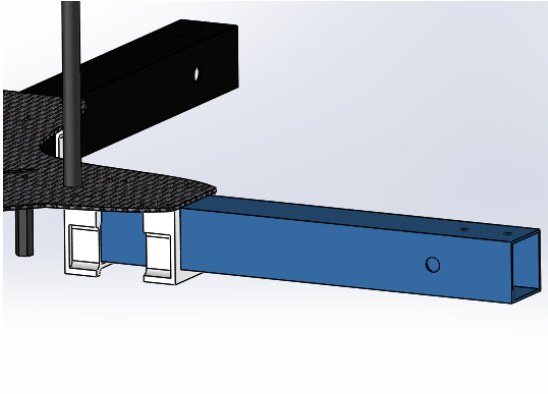
Part Name	Qty.	Image
Clamp 1	4	
Clamp 2	4	
CF Motor Arm	4	

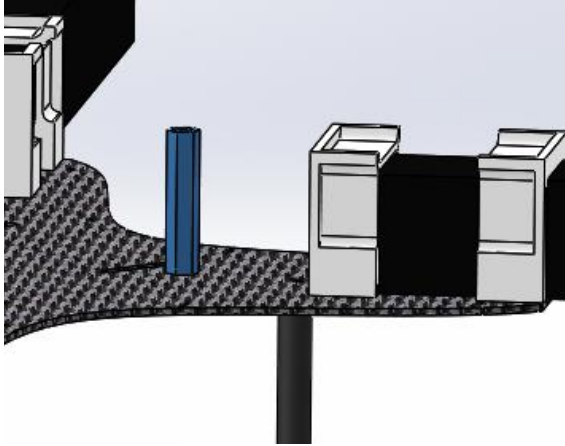
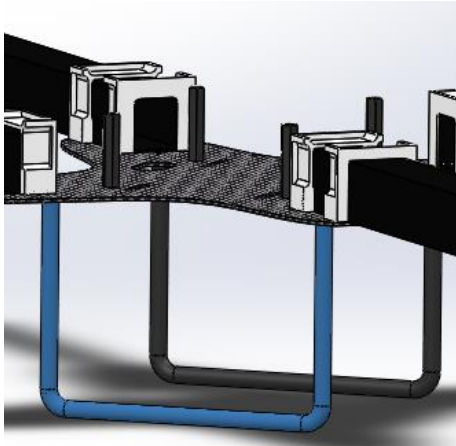
Nylon Spacer	4	
Landing Gear	2	

These parts are bonded with mating part as follows:

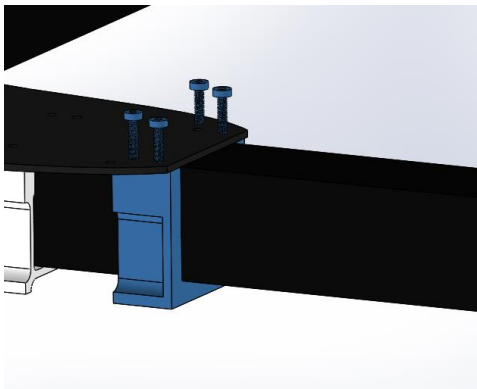
Part Name	Mating Part Name	Bonded Using	Image
Clamp 1	Carbon Fiber Base Plate	Four clamps are Fastened through M2 x 10 mm SS bolt on Carbon Fiber Base Plate and thread locker is applied while fastening.	

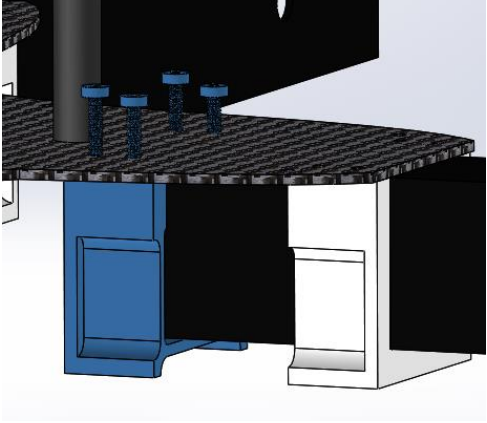
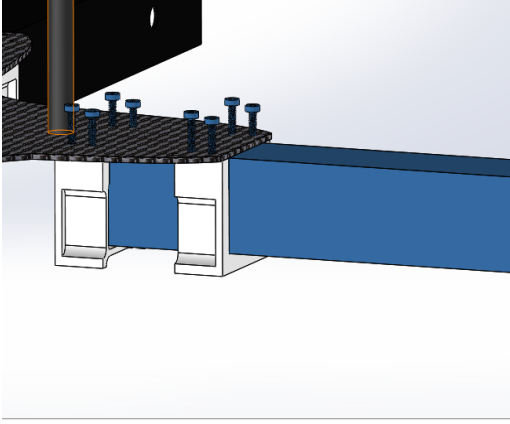
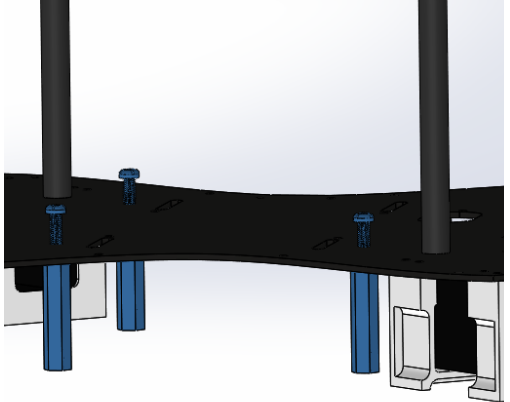
Clamp 2	Carbon Fiber Base Plate	Four clamps are Fastened through M2 x 10 mm SS bolt on Carbon Fiber Base Plate and thread locker is applied while fastening.	
CF Motor Arm	Carbon Fiber Base Plate, Clamp 1 & Clamp 2	All four arms are Fastened through M2 x 10mm SS bolt to the Carbon Fiber Base Plate using clamp1 and clamp2.	
Nylon Spacers	Carbon Fiber Base Plate	All four Nylon Spacer are Fastened through M3 x 10mm SS bolt to the Carbon Fiber Base Plate and secured with thread locker.	

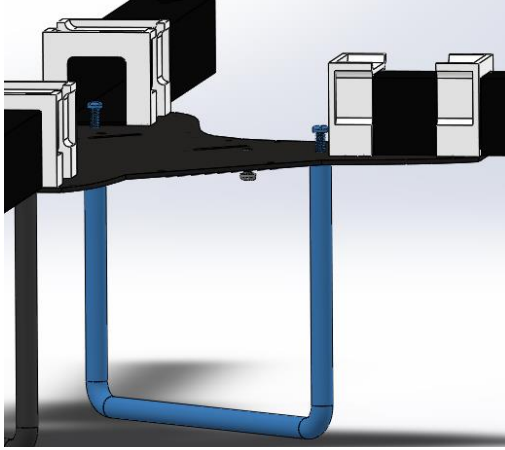
Landing Gear	Carbon Fiber Base Plate	Fastened through M3 x8 mm SS bolt and secured with thread locker	
--------------	-------------------------	--	--

All of the bolts used for fastening for primary structural elements are secured using Thread Loacker Adhesion. Trying to remove the fasteners can lead to the damage of any critical component and hampering drone life.

10. Safety Instructions & Precautions

Always prioritize safety when operating your Surveyaan V1 drone. Here are key precautions to remember for a successful and safe flight:

Operational Limitations:

1. Visual Line of Sight (VLOS) Only: The Surveyaan V1 is designed for VLOS operations only. This means you must maintain a clear visual line of sight with the drone at all times during flight.
2. High-Intensity Radiation Warning: Avoid operating the drone in environments with High-Intensity Radiated Fields (HIRF), as this can interfere with its electronic systems.

Flight Environment:

3. Favorable Weather Conditions: The Surveyaan V1 is built for normal weather conditions. For optimal surveying performance, ensure good visibility and avoid flying in rain, snow, strong winds, or extreme temperatures. The drone lacks ingress protection, so avoid exposing it to excessive dust or moisture.
4. Clear Flight Path: Always choose open areas for flight and ensure the planned flight path is free of obstacles like buildings, trees, power lines, or people.

Pre-Flight Checks:

5. Secure and Charged Battery: Verify the battery is securely fastened with the straps and fully charged for the planned flight duration.
6. Motor Check: Before takeoff, use the control app to check the motors for proper function and listen for any unusual noises during rotation.
7. Minimum Takeoff Distance: Maintain a minimum safe distance of 10 meters from the takeoff position before initiating flight.
8. Propeller Security: Ensure all propellers are securely tightened to prevent any unusual occurrences.

Landing Considerations:

9. **Controlled Landing:** The Surveyaan V1 is a micro-category drone and does not have a dedicated shock-absorbing landing gear. Its compact size and lightweight design help minimize impact during landings.
10. **Gentle Descent:** The pilot should prioritize a controlled descent throughout the landing process to ensure a smooth touchdown.

Post-Flight Inspection:

11. **Landing Gear Inspection:** After landing, carefully inspect the landing gear for any dents, cracks, damage, or signs of wear and tear. Address any issues before the next flight.

By following these safety instructions and conducting thorough pre-flight checks, you can ensure a safe and enjoyable flying experience with your Surveyaan V1 drone.

11. Troubleshooting

The troubleshooting section of this manual provides guidance and solutions for common issues that you may encounter while operating the Surveyaan V1 drone. Troubleshooting is an essential skill that allows users to identify and resolve problems effectively, ensuring smooth and reliable drone operation.

11.1. Drone Not Connected

If your drone is powered on and the strobe lights are flashing at intervals of 1 second, but the Surveyaan V1 control app is not connecting, please follow these troubleshooting steps:

- Ensure that you are logged in with the correct drone ID. You can try logging out and logging back in to ensure proper authentication.
- Make sure that you are connected to the Ground Unit's Wi-Fi network. Check your Wi-Fi settings on your device and ensure that you are connected to the correct network.

- After logging in, ensure that your internet connection is turned off and only Wi-Fi is enabled. This will prevent any interference from cellular data and ensure a stable connection to the drone.
- Check the antenna connections both on the drone and the Ground Unit. Ensure that the antennas are properly connected and securely attached. Loose or improperly connected antennas can cause connection issues.

By following these steps, you can troubleshoot the connection problem between the Surveyaan V1 control app and the drone. If the issue persists, please consult the customer support.

11.2. Motor and Propeller Problems

- If a motor fails to spin or exhibits abnormal behavior, check the connections and wiring.
- Ensure that the propellers are installed correctly, tightened securely.
- Inspect the propellers for any damage, wear, or obstruction.

11.3. Camera Connection issues

- Before every flight, you must check whether the camera is connected by taking 2-3 manual photos while it is on the ground. Also, ensure that the proper mode is selected in the camera.
- For mapping and survey purposes, the camera should be in photos mode, and the lens type should be set to linear.
- If you are experiencing difficulty connecting with the camera, please check the last 4 digits of the camera's serial number.
- If the issue still persists, please try resetting the camera by removing and reinserting the battery.

11.4. Error Messages and Indicators

Look to the notes section in the control app for any error message received during flight operations and you can send to our customer support.

1. **Accels Inconsistent:** This error comes before flight or before arming the motor if there is a requirement of drone accelerometer calibration. Steps to do the calibration can be found in Section 6.5 of Flight Manual.

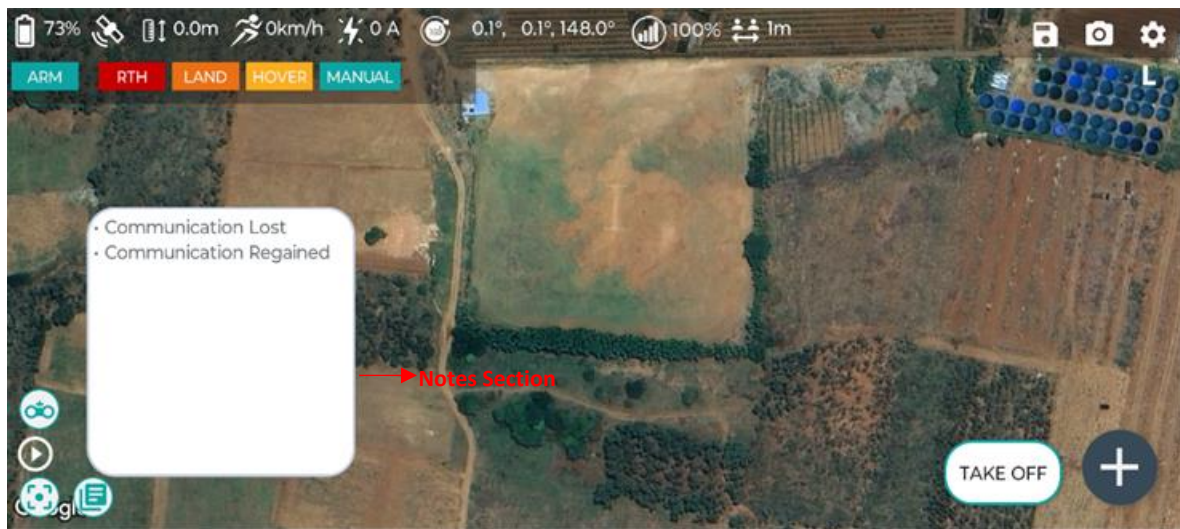

Figure 17: Surveyaan V1 GCS app main dashboard

2. **Compass Inconsistent:** This error may arise during the pre-arm check if there is a significant mismatch in the values of both compasses, surpassing a predefined limit. For detailed instructions on how to perform compass calibration, please refer to the flight manual, where you will find step-by-step guidance to address this issue effectively.

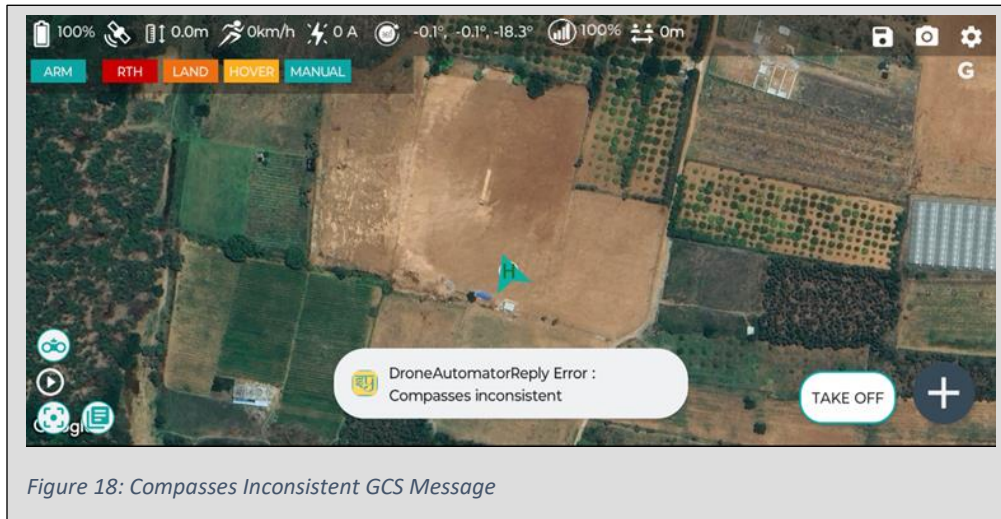

Figure 18: Compasses Inconsistent GCS Message

3. **Gyro Inconsistent:** This error may arise if gyro sensor readings go beyond a predefined limit. This can also be done by following the steps defined in flight manual.

4. **Waiting for GPS or Bad GPS:** This error comes when number of satellite is not sufficient for flying the drone or the environment is not open to fly.

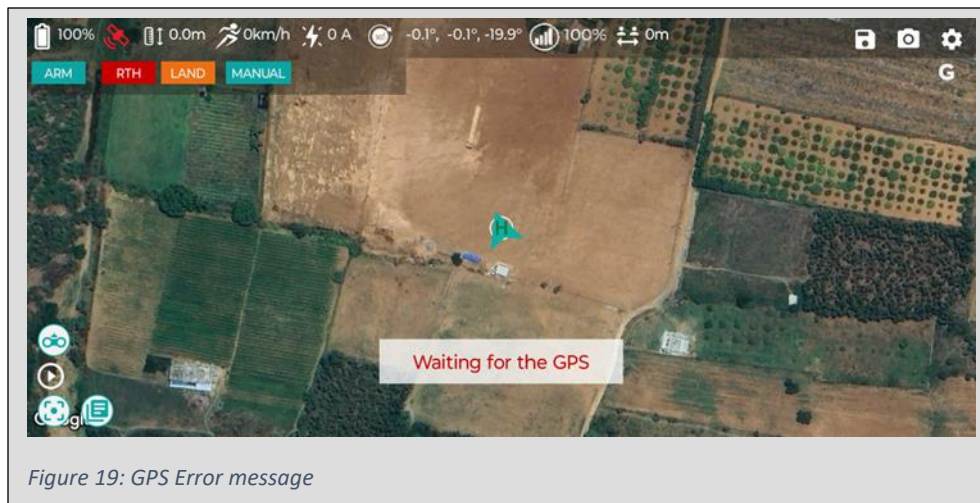
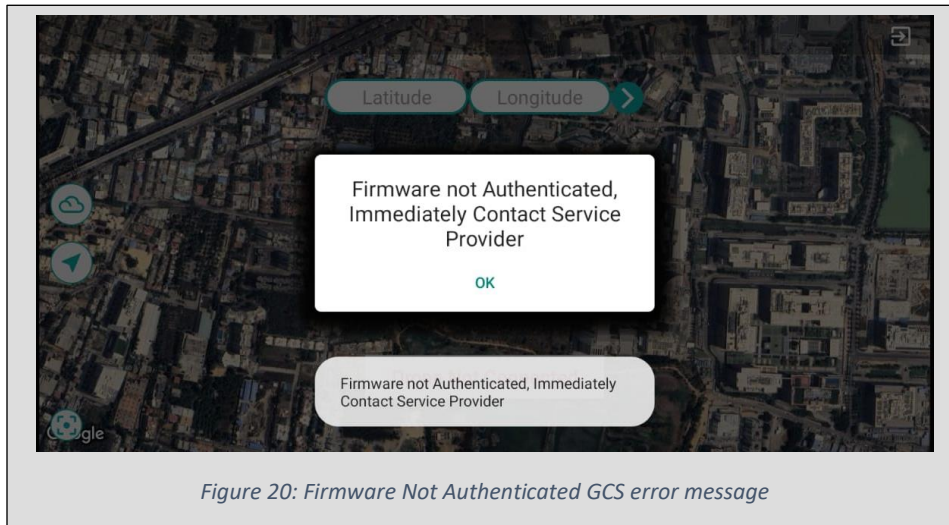
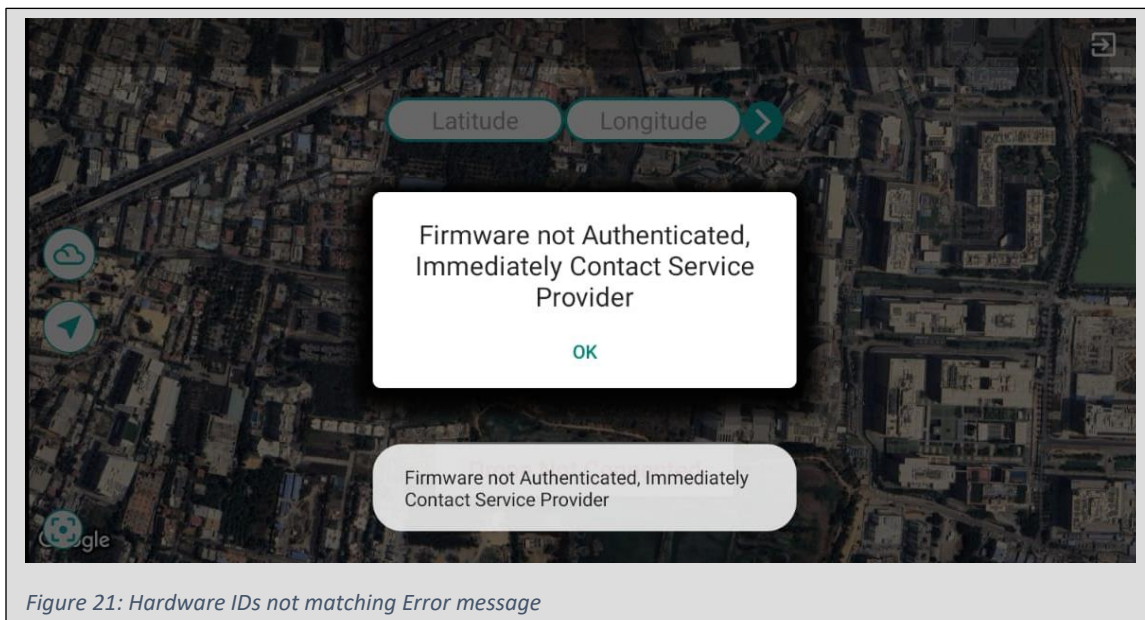

Figure 19: GPS Error message

5. **Firmware Not Authenticated:** This error comes when somehow any tampering is done with original firmware.



6. **Serial Ids not matching:** If there is unauthorized changes of critical components like flight controller, on-board computer, communication module, then this error will be thrown in GCS app.



12. Warranty Terms & Conditions

Nibrus Technologies Private Limited, the owner of brand Surveyaan, hereinafter referred to as the Guarantor, shall guarantee good quality and proper functioning of the purchased device if used in the manner appropriate for the purpose thereof and in accordance with the operational manual (most updated one, if that is not supplied with the product, please visit live document link as specified by the guarantor), and shall provide warranty service subject to the following conditions:

1. This warranty covers the defects resulting from defective parts, materials or manufacturing if such defects are revealed during the period of 12 months since the date of purchase.
2. The device is considered defective if it fails to perform function as indicated in the operational manual, technical specification or any other document or media related to the equipment, and the failure is due to internal device characteristic.
3. The defects and damages revealed during the warranty period shall be removed free of charge by the Guarantor service center located at #196/26, HS Jayanthi Building, Kaikondrahalli, Bellandur, Bengaluru Urban, Karnataka – 560037, within one month since the date of delivering the device to the service center.
4. Removing defects and damages time could be extended in case replacement parts are imported from outside India.
5. The Guarantor reserves the right to charge the Warranty beneficiary with the costs of service, transportation, insurance and custom clearance if the defect doesn't fall within the scope of this warranty or the device has not been proven defective.
6. Warranty services will be provided under the following conditions:
 - a. Immediately and effectively notify Guarantor about determined device's defect and cease any uses of it.

- b. The marked device along with copy of commercial invoice should be delivered to Guarantor's service center.
 - c. The serial number of the delivered defective device must match the serial number sold to customer.
 - d. The device should be delivered together with detailed and readable description of the technical problem.
 - e. The device should have intact warranty seals of the Guarantor and should be appropriately packaged during its loading, transportation and unloading.
 - f. The shipment to the Guarantor service center must be arranged and paid by the customer, which can be given as a credit to the customer in Surveyaan GeoWorkspace service.
7. The Guarantor reserves the right to replace the defective device or its component with a free-of-defects equivalent thereof, provided that such equivalent ensures efficiency and functionality equal to or higher than the original device or component. The replaced defective device or components shall become the property of the Guarantor.
 8. The Warranty period is extended by the time during which the repaired device stays in the Guarantor's Service Center.
 9. This warranty does not cover the loss of life, money or profit that has happens due to malfunctioning of the product.
 10. This warranty does not cover the damages to payload happens due to malfunctioning of the product.
 11. This warranty does not cover the loss of data due to malfunctioning of the product.
 12. The Guarantor shall not be held responsible for any failure in performance of the obligations as stipulated in this Warranty, whenever such failure is caused by a force majeure afflicting the Guarantor or the manufacturer of the device. Force majeure means any event or circumstance beyond reasonable control of the Guarantor which prevents

the Guarantor from performing the obligations stipulated in this Warranty, or results in the performance of the Warranty services that is inconsistent with the conditions stated herein, and which could not have been foreseen by the Guarantor acting with the professional accuracy at the moment of assuming obligations under this Warranty.

13. The Guarantor reserves the right to refuse to provide any Warranty services if it would result in a breach of applicable laws.
14. The warranty is not applicable:
 - a. Warranty is not applicable in case of inappropriate use of the device. Although they are mentioned in the manual but few important ones are also mentioned below:
 - i. The battery should be tightened properly with the aircraft using the straps provided. Loose battery may cause fatal damage to the aircraft while it is flying.
 - ii. Users should plan the mission in such a way that there should not be any static objects such as buildings, tree, towers etc. present at the mission altitude considering +5m/-5m tolerance.
 - iii. Users should check the conditions of motor by arming them before every flight. If they are not working properly, Users should not provide the flying mission to the drone.
 - iv. Users should inspect the condition of aircraft body and propeller before providing the flying mission.
 - b. Warranty is not applicable in case users are flying in or near to restricted or sensitive areas notified by Government of India such as airports, military bases, state assemblies, Parliament, International border etc.
 - c. Warranty is not applicable in case of damages caused by act of God, flood, fires, lightening or other natural disasters, wars, unexpected

- events, inappropriate voltage, defective supply materials or other external factors.
- d. Warranty is not applicable if the aircraft has been tempered with by the Warranty beneficiary or any other person in any way, including reconfiguration, repair, willful constructional variations, modifications and adjustments.
 - e. Warranty is not applicable if damages are due to user's fault or lack of knowledge.

13. Customer Support

For customer support, please reach out to our dedicated support team for any assistance or inquiries. Our team is ready to provide prompt and reliable support to address your concerns and ensure a positive experience with our product. Feel free to contact us through the provided customer support channels, including phone or email. We are here to help you!

Contact

Email: surveyaansupport@nibrus.in

Phone: +91 9606922556

SurveGyaan by Surveyaan: An Education Initiative by Nibrus Technologies Pvt. Ltd.

Medium: <https://surveygyaan.medium.com/>

YouTube: <https://www.youtube.com/@surveygyaanbysurveyaan/videos>

14. Policy Update

Flight Operator Manual will be reviewed within 1 year from the date of issue or whenever there is a change, whichever is earlier.